

SLAYTON 36

Model: #SLA-36
Direct Vent Linear Fireplace

KOZY HEAT
FIREPLACES
HUSSONG MFG. CO, INC.

Installation and Operation Manual

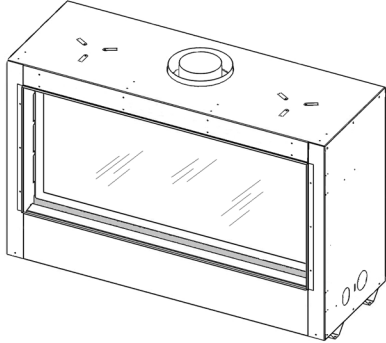

English and French Installation Manuals
Available Through Your Local Dealer or Visit
Our Website at www.kozyheat.com



INSTALLER: Leave this manual with the appliance.
CONSUMER: Retain this manual for future reference.

This appliance may be installed in an aftermarket, permanently located, manufactured home (USA only) or mobile home, where not prohibited by local codes.

This appliance is only for use with the type of gas indicated on the rating plate. This appliance is not convertible for use with other gases, unless a certified kit is used.

WARNING: If the information in these instructions are not followed exactly, a fire or explosion may result causing property damage, personal injury, or loss of life.

—Do not store or use gasoline or other flammable vapors and liquids in the vicinity of this or any other appliance.

—WHAT TO DO IF YOU SMELL GAS

- Do not try to light any appliance.
- Do not touch any electrical switch; do not use any phone in your building.
- Immediately call gas supplier from a neighbors phone. Follow the gas supplier instructions.
- If you cannot reach your gas supplier, call the fire department.

—Installation and service must be performed by a qualified installer, service agency or the gas supplier.

WARNING

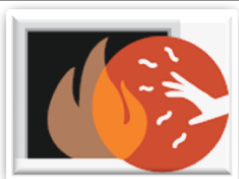

**HOT GLASS WILL CAUSE BURNS.
DO NOT TOUCH GLASS UNTIL COOLED.
NEVER ALLOW CHILDREN TO TOUCH GLASS.**

A barrier designed to reduce the risk of burns from the hot viewing glass is provided with this appliance and shall be installed.



We recommend that our gas hearth products be installed and serviced by professionals who are certified in the U.S. by the National Fireplace Institute® (NFI) as NFI Gas Specialists.

Tested &
Listed By



Portland
Oregon USA

OMNI-Test Laboratories, Inc.
Report No. 216-F-39b-6.5

October 2013
SLA-36-REV-02

fire-parts.com

Read this manual before installing or operating this appliance.
Please retain this owner's manual for future reference.

CONGRATULATIONS!

We welcome you as a new owner of a Kozy Heat gas fireplace. Kozy Heat products are designed with superior components and materials; assembled by trained craftsmen who take pride in their work. The burner and valve assembly are 100% test-fired, and the complete fireplace is thoroughly inspected before packaging to ensure you receive a quality product. Our commitment to quality and customer satisfaction has remained the same for over 30 years. We offer a complete line of gas and wood fireplaces, unique cabinets and stylish accessories to complement any décor. Adding a fireplace is one of the best ways to increase the value of your home, and we are proud to offer a network of dealers throughout the country to help make your experience everything you imagine. We pride ourselves in being dedicated not only to functionality and reliability, but also customer safety. We offer our continual support and guidance to help you achieve the maximum benefit and enjoyment from your Kozy Heat gas fireplace.

Jim Hussong
President

Dudley Hussong
Board Chairman



Homeowner Reference Information

We recommend you record the following information:

Model Name: _____ Date purchased/installed: _____

Serial Number: _____ Location on fireplace: _____

Dealership purchased from: _____ Dealer Phone: _____

Notes: _____

fire-parts.com

TABLE OF CONTENTS

HOMEOWNER REFERENCE INFORMATION	1				
TABLE OF CONTENTS	2				
1.0 INTRODUCTION	3				
1.1	Appliance Certification	3			
1.2	Safety Information	3			
1.3	Commonwealth of Massachusetts Requirements	4			
2.0 SPECIFICATIONS	5				
2.1	Components	5			
2.2	BTU Specifications	5			
2.3	Gas Information	5			
2.4	Placement Clearance Requirements	6			
2.5	Installation Overview	6			
3.0 FRAMING	7				
3.1	Fireplace Dimensions	7			
3.2	Clearances to Combustibles	8			
3.3	Wall Enclosure Rough Opening	8			
3.4	Minimum Framing Dimensions	8			
3.5	Hearth Construction and Requirements	9			
3.6	Vent Termination Framing	9			
4.0 RECESS CONSTRUCTION	10				
4.1	Television Positioning Considerations	10			
4.2	Recess Framing and Clearances	10			
5.0 MANTEL REQUIREMENTS	11				
5.1	Mantel Projections	11			
6.0 TYPICAL FRAMING OPTIONS	12				
6.1	Horizontal Installation	12			
6.2	Vertical Installation	12			
6.3	Corner Installation	12			
7.0 FACING AND FINISHING	13				
8.0 FIREPLACE PREPARATION	14				
8.1	Stand-Off Components	14			
8.2	Nailing Flange Assembly and Installation	15			
9.0 GAS LINE CONNECTION	16				
9.1	Gas Conversion	16			
9.2	High Altitude Installations	16			
10.0 WIRING SCHEMATICS	17				
11.0 VENTING	18				
11.1	Approved Vent Systems	18			
11.2	Elbows	18			
11.3	Vent Cap Location Clearances	19			
11.4	Venting for Horizontal Terminations	20			
11.5	Venting for Vertical Terminations	21			
11.6	Restrictor Assembly and Installation	21			
11.7	Horizontal and Vertical 8" x 5" Combination Venting	22			
11.8	Horizontal and Vertical 6-5/8" x 4" Reducer Combination Venting	23			
11.9	#800-1 Series Direct Vent Termination Kit(s)	24			
11.10	Vertical Vent Termination Clearances	25			
12.0 #970 HEAT DUCT KIT	26				
12.1	Specifications	26			
12.2	Attach Duct to Fireplace	26			
12.3	Install Register Mounting Frame and Junction Box	27			
12.4	Install and Wire Fan Assembly	27			
12.5	Run and Secure Duct Pipe	28			
12.6	Complete the Installation	28			
			12.7	Operating Instructions	28
			12.8	Maintenance	28
13.0 FIREPLACE SETUP	29				
13.1	Glass Frame Assembly	29			
13.2	Safety Barrier Installation	29			
13.3	Light Kit	31			
13.4	Glass Media	31			
13.5	Control Board	32			
14.0 CONTROL SYSTEM COMPONENTS	33				
14.1	Remote Control	33			
14.2	Gas Valve	33			
14.3	Pilot Assembly	33			
15.0 SYSTEM OPERATION	34				
15.1	Initializing the System for the First Time	34			
15.2	Temperature Display	34			
15.3	Turn on the Appliance	34			
15.4	Turn off the Appliance	34			
15.5	Manually Control Flame with Remote Control	34			
15.6	Remote Control Thermostat Operation	35			
15.7	Fan Speed Control	35			
15.8	Accent Light Kit	35			
15.9	Key Lock	35			
15.10	Low Battery Detection	36			
15.11	Continuous Pilot / Intermittent Pilot	36			
15.12	Resetting System for Manual Operation	36			
15.13	Automatic Safety Restart	36			
15.14	Lock Out Information	37			
15.15	Additional Diagnostic Indications Information	37			
16.0 LIGHTING AND SHUTDOWN	38				
16.1	Operating Instructions	39			
16.2	To Turn Gas Off to Appliance	39			
17.0 PRESSURE TESTING	40				
17.1	Inlet Pressure Test	40			
17.2	Manifold Pressure Test	40			
18.0 FINALIZING THE INSTALLATION	41				
18.1	Flame Appearance	41			
18.2	Burner Tube Venturi	41			
18.3	Restrictors	42			
19.0 TROUBLESHOOTING	43				
19.1	Pilot Will Not Light / Stay Lit	43			
19.2	Pilot Flame Always On / Will not Extinguish	43			
19.3	Main Flame Will Not Light	43			
19.4	Pilot and Burner Extinguish While in Operation	44			
19.5	Glass Sooting	44			
19.6	Flame Burns Blue and Lifts Off Burner	44			
19.7	No Reaction to Command	44			
20.0 MAINTENANCE	45				
20.1	Control Board System	45			
20.2	Fan	45			
20.3	Vent System	45			
20.4	Glass Assembly	45			
21.0 REPLACEMENT PARTS LIST	46				
LIMITED WARRANTY	47				
LIFETIME WARRANTY	48				

1.0 INTRODUCTION

1.1 Appliance Certification

This appliance has been tested by OMNI-Test Laboratories located in Portland, Oregon and complies with:

ANSI Z21.88a-2012/CSA 2.33a-2012, "Vented Gas Fireplace Heaters"
CGA 2.17-M91 (R2009), "Gas-Fired Appliances for Use at High Altitudes"
CSA P.4.1-2009, "Testing Method for Measuring Annual Fireplace Efficiency"

This installation must conform with local codes, or in the absence of local codes, with the *National Fuel Gas Code, ANSI Z223.1/NFPA 54*, or the *Natural Gas and Propane Installation Code, CSA B149.1*

This appliance, when installed, must be electrically grounded in accordance with local codes, or in the absence of local codes, with the *National Electrical Code, ANSI/NFPA 70*, or the *Canadian Electrical Code, CSA C22.1*

1.2 Safety Information

- Installation and repair should be done only by a qualified service person. The appliance should be inspected by a qualified service person before use. Annual inspection by a qualified service person is required to maintain warranty. More frequent cleaning may be required due to excessive lint from carpeting, bedding materials, etc. It is imperative that control compartments, burners, and circulation air passageways of the appliance be kept clean.
- If this appliance is installed directly on carpeting, tile, or other combustible material other than wood flooring, the appliance shall be installed on a metal or wood panel extending the full width and depth of the appliance.
- Children and adults should be alerted to the hazards of high surface temperatures and should stay away to avoid burns or clothing ignition.
- Young children should be carefully supervised when they are in the same room as the appliance. Toddlers, young children, and others may be susceptible to accidental contact burns. A physical barrier is recommended if there are at-risk individuals in the house. To restrict access to a fireplace or stove, install an adjustable safety gate to keep toddlers, young children, and other at-risk individuals out of the room and away from hot surfaces.
- Clothing or other flammable material should not be placed on or near the appliance.
- Adequate accessibility clearances for servicing and proper operation must be maintained.
- This appliance must not share, or be connected, to a chimney flue serving any other appliance.
- Keep area around the appliance clear of combustible materials, gasoline, and other flammable vapor and liquids.
- The flow of combustion and ventilation air must not be obstructed.
- Due to high temperatures, the appliance should be located out of traffic and away from furniture and draperies.
- The glass front, or any part removed for servicing the appliance, must be replaced prior to operating the appliance. Work should be done by a qualified service technician.
- Clean glass only when cool and only with non-abrasive cleansers.
- **WARNING: DO NOT OPERATE APPLIANCE WITH THE GLASS/FRAME ASSEMBLY REMOVED, CRACKED, OR BROKEN. REPLACEMENT OF THE GLASS SHOULD ONLY BE PERFORMED BY A LICENSED OR QUALIFIED SERVICE PERSON.**
- The glass assembly, Part #SL36-057T, shall only be replaced as a complete unit, as supplied by Hussong Mfg. Co., Inc. DO NOT SUBSTITUTE MATERIALS.
- Do not strike or slam glass assembly.
- A safety barrier designed to reduce the risk of burns from the hot viewing glass is provided with this appliance and shall be installed.
- Any safety screen, guard, or barrier removed for servicing the appliance must be replaced prior to operating the appliance.
- If the safety barrier becomes damaged, the barrier shall be replaced with the manufacturer's barrier for this appliance.
- For use only with the following safety barriers: Part Numbers SL36-MSF, SL36-RSF, SL36-BSF, or SL36-CXCF, as supplied by Hussong Mfg. Co., Inc.
- Under no circumstances should any solid fuel (wood, coal, paper, cardboard, etc.) be used in this appliance.
- Keep burner and control compartment clean.
- Do not use this fireplace if any part has been under water. Immediately call a qualified service technician to inspect this appliance and to replace any part of the control system and any gas control which has been under water.

1.3 Commonwealth of Massachusetts Requirements

The following requirements reference various Massachusetts and national codes not contained in this manual.

For all sidewall horizontally vented gas fueled equipment installed in every dwelling, building or structure used in whole or in part for residential purposes, including those owned or operated by the Commonwealth and where the side wall exhaust vent termination is less than (7) feet above finished grade in the area of the venting, including but not limited to decks and porches, the following requirements shall be satisfied:

1.3.1 Installation of Carbon Monoxide Detectors

At time of installation of side wall horizontally vented gas fueled equipment, the installing plumber or gas-fitter shall observe that a hard wired carbon monoxide detector with an alarm and battery back-up is installed on the floor level where the gas equipment is to be installed. In addition, the installing plumber or gas-fitter shall observe that a battery operated or hard wired carbon monoxide detector is installed on each additional level of the dwelling, building or structure served by the side wall horizontal vented gas fueled equipment. It shall be the responsibility of the property owner to secure the services of qualified licensed professionals for the installation of hard wired carbon monoxide detectors.

In the event that the side wall horizontally vented gas fueled equipment is installed in a crawl space or attic, the hard wired carbon monoxide detector with alarm and battery back-up may be installed on the next adjacent floor level.

In the event that the requirements of this subdivision can not be met at the time of completion of installation, the owner shall have a period of thirty (30) days to comply with the above requirements; provided, however, that during said thirty (30) day period, a battery operated carbon monoxide detector with an alarm shall be installed.

1.3.2 Approved Carbon Monoxide Detectors

Each carbon monoxide detector as required in accordance with the above provisions shall comply with NFPA 720 and be ANSI/UL 2034 listed and IAS certified.

1.3.3 Signage

A metal or plastic identification plate shall be permanently mounted to the exterior of the building at a minimum of eight (8) feet above grade directly in line with the exhaust vent terminal for the horizontally vented gas fueled heating appliance or equipment. The sign shall read, in print no less the one-half inch (1/2) in size, **"GAS VENT DIRECTLY BELOW. KEEP CLEAR OF ALL OBSTRUCTIONS"**.

1.3.4 Inspection

The state or local gas inspector of the side wall horizontally vented gas fueled equipment shall not approve the installation unless, upon inspection, the inspector observes carbon monoxide detectors and signage installed in accordance with the provisions of 248 CMR 5.08 (2) (a) 1 through 4.

1.3.5 Exemptions

The following equipment is exempt from 248 CMR 5.08 (2) (a) 1 through 4: The equipment listed in Chapter 10 entitled "Equipment Not Required To Be Vented" in the most current edition of NFPA 54 as adopted by the Board; and Product Approved side wall horizontally vented gas fueled equipment installed in a room or structure separate from the dwelling, building or structure used in whole or in part for residential purposes.

1.3.6 Manufacturer Requirements

Gas Equipment Venting System Provided

When the manufacturer of Product Approved side wall horizontally vented gas equipment provides a venting system design or venting system components with the equipment, the instructions provided by the manufacturer for installation of the equipment and the venting system shall include:

- Detailed instructions for the installation of the venting system design or the venting system components; and
- A complete parts list for the venting system design or venting system.

Gas Equipment Venting System Not Provided

When the manufacturer of Product Approved side wall horizontally vented gas equipment does not provide the parts for venting the flue gases, but identifies "special venting systems", the following requirements shall be satisfied by the manufacturer:

- The referenced "special venting systems" instructions shall be included with the appliance or equipment installation instructions and;
- The "special venting systems" shall be Product Approved by the Board, and the instructions for that system shall include a parts list and detailed installation instructions.

A copy of all installation instructions for all Product Approved side wall horizontally vented gas fueled equipment, all venting instructions, all parts lists for venting instructions, and/or all venting design instructions shall remain with the appliance or equipment at the completion of the installation.

2.0 SPECIFICATIONS

2.1 Components

2.1.1 Components List

PART NUMBER	DESCRIPTION
SL36-150	Control Board Assembly
SL36-135	Burner Assembly
SL42-BLK	Light Kit
SL36-057T	Glass Frame Assembly
700-408	Remote Control
600-002	Double Receptacle Assembly
SL36-085	5 in. Restrictor Plate
SL42-028	Fan or Blower Assembly
AL36-DRAM	Rock / Driftwood Accent Media
SL42-500	Driftwood Log Set
SL42-RAM	Rock Accent Media
#970 Heat Duct Kit	Heat Duct Kit

2.1.2 Additional Components Required

- Vent System: See 11.1, Approved Vent Systems, on page 18 for details.
- Glass Media: Various colors available. See your dealer for details.

2.2 BTU Specifications

	NATURAL GAS	LP GAS
Orifice Size	#37	#.0625
Input BTU/Hr. (kW)	33,000 BTU/hr (9.67 kW)	33,000 BTU/hr (9.67 kW)
Minimum Input BTU/Hr. (kW)	17,000 BTU/hr (4.98 kW)	17,000 BTU/hr (4.98 kW)

2.3 Gas Information

	NATURAL GAS	LP GAS
Minimum Inlet Gas Pressure	5" WC (1.25 kPa) (7" WC [1.74 kPa] recommended)	12" WC (2.99 kPa) (recommended)
Maximum Inlet Gas Pressure	10.5" WC (2.62 kPa)	13" WC (3.24 kPa)
Manifold Pressure (High)	3.8" WC (.95 kPa)	11" WC (2.74 kPa)
Manifold Pressure (Low)	1.1" WC (.27 kPa)	2.9" WC (.72 kPa)

2.3.1 High Altitude Installations

ATTENTION

In the USA: This appliance may be installed at higher altitudes. Please refer to your American Gas Association guidelines which state the sea level rated input of Gas Designed Appliances installed at elevations above 2,000 ft. (610 m) is to be reduced 4% for each 1,000 ft. (305 m) above sea level. Refer also to National Fuel Gas Code, ANSI Z223.1 / NFPA 54, local authorities, or codes which have jurisdiction in your area regarding the de-rate guidelines.

In Canada: When the appliance is installed at elevations above 4,500 ft. (1,372 m), the certified high altitude rating shall be reduced at the rate of 4% for each additional 1,000 ft. (305 m). Refer also to CSA-B149.1 Natural Gas and Propane Installation Code, Local authorities, or codes which have jurisdiction in your area regarding the de-rate guidelines.

2.4 Placement Clearance Requirements

- This fireplace must be installed on a level surface capable of supporting fireplace and venting.
- The fireplace must be placed directly on wood or a non-combustible surface (not linoleum or carpet), extending entire depth and width of the fireplace.
- Due to high surface temperatures, fireplace should be located out of traffic and away from furniture and draperies.
- This fireplace may be installed in a bedroom.
- Please be aware of the large amount of heat this fireplace will produce when determining a location.

2.5 Installation Overview

NOTE

The qualified installer should follow the procedure best suited for the installation.

1. Frame an opening for fireplace, allowing for vent installation and type of installation (corner or flat wall application).
2. If masonry (optional) is used, prepare foundation for the masonry load. A lintel is required to support the added weight above fireplace.
3. Attach stand-off brackets and nailing flanges to fireplace.
4. Insert fireplace into framing.
5. Install hearth (if applicable).
6. Complete gas line installation.
7. Complete electrical hook-up. Install any standard or optional electrical components at this time.
8. Complete venting installation.
9. Secure fireplace to framing with nailing flanges. Verify all clearances at this point.
10. Install facing material, mantel, or cabinetry; allowing room for the safety barrier.
11. Install glass media (required).
12. Install finishing material, optional surrounds.
13. Verify proper operation of fireplace and all components.

3.0 FRAMING

3.1 Fireplace Dimensions

WARNING

All stand-off brackets must be attached to fireplace. Do not remove. Top stand-off brackets are not load bearing.

Non-combustible zone: Top stand-offs provide 7-3/4 in. (198 mm) minimum clearance to header; side stand-offs / framing brackets provide 2-1/2 in. (64 mm) minimum clearances; back stand-offs provide 3-3/16 in. (80 mm) minimum clearances; attached bottom stand offs allow 1-3/8 in. (35 mm) clearances. Use only non-combustible material in this area for entire width of fireplace. Do not use wood, sheetrock etc. in this zone. Other clearances apply. All clearances must be maintained.

Figure 3.1, Fireplace Dimensions

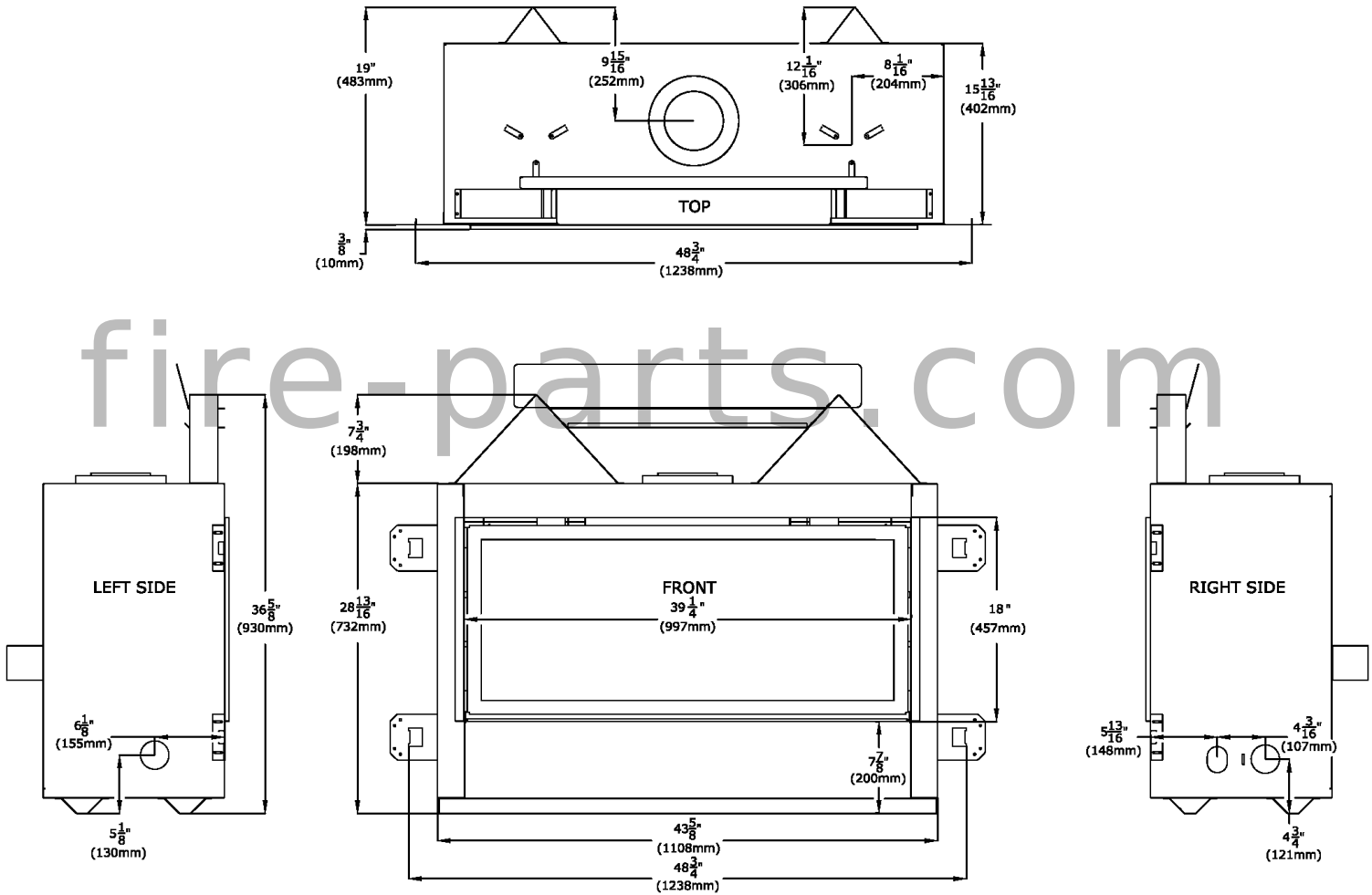

Table 3.1, Slayton-36 Dimensions

Description	Height	Width	Back Width	Depth	Opening Width	Opening Height	Top Stand-off Height	Back to Vent Center
Inches	28-13/16	43-5/8	43-5/8	15-13/16	39-1/4	18	7-3/4	9-15/16
Millimeters	732	1108	1108	402	997	457	198	252

3.2 Clearances to Combustible Material

Table 3.2, Appliance Enclosure Clearances		
Top of appliance stand-offs to framing	0 in.	0 mm
From appliance left side & right side stand-offs	0 in.	0 mm
From appliance back stand-offs	0 in.	0 mm
From bottom stand-offs	0 in.	0 mm
Top of finishing edge to ceiling	36 in.	914 mm
Side of finishing edge to adjacent sidewall	6 in.	152 mm
Appliance front to combustibles	36 in.	914 mm
Mantel projection 1 in. (25 mm) deep from fireplace finishing edge	14-1/4 in.	362 mm

3.3 Wall Enclosure Rough Opening

- Determine whether the wall surface will be flush with the fireplace face, in which the wall surface and fireplace will be covered with non-combustible material such as tile; or, if the framing will be flush with the fireplace face, which results in a flat wall appearance.
- Framing studs must maintain 1 in. (25 mm) clearances to venting. Please refer to Figure 3.2, Framed Opening, for guidance.
- Framing dimensions should allow for wall covering thickness and fireplace facing materials. If using a hearth, adjust rough opening size as necessary to maintain clearance requirements.
- This fireplace may be elevated off the floor as shown in Figure 3.2, provided it is properly supported by framing materials, and ceiling clearances are maintained.
- If installing optional #970 Heat Duct Kit, refer to 12.0 #970 Heat Duct Kit, on page 26.

3.4 Minimum Finished Opening Dimensions

WARNING

PROVIDE ADEQUATE CLEARANCES AROUND AIR OPENINGS INTO THE COMBUSTION CHAMBER.
DO NOT OBSTRUCT UPPER AND LOWER GRILL OPENINGS. ROOM AIR ENTERS THROUGH LOWER PASSAGE, IS THEN HEATED, AND EXITS THROUGH UPPER PASSAGE. BLOCKING THESE PASSAGES MAY RESULT IN OVERHEATING, CREATING A POTENTIALLY HAZARDOUS SITUATION.

Table 3.3, Minimum Finished Opening Dimensions	
(Opening Bottom to Header) Height	36-5/8 in. (930 mm)
(Opening Bottom to Ceiling) Height	62-1/4 in. (1581 mm)
Width	48-3/4 in. (1238 mm)
Depth**	19 in. (483 mm)
<p>** 19 in. (483 mm) represents the minimum distance from the front of the fireplace to back wall of framing. This is the minimum wall depth required for the wall surface material to cover the fireplace front.</p> <p>If wall surface is desired to be flush with the fireplace face, subtract 1/2 in. (13 mm) (standard non-combustible board depth) from this dimension. If using another material, adjust accordingly.</p>	
<p>* Refer to Figures 3.3—3.5 on page 9 for horizontal vent termination framing.</p>	

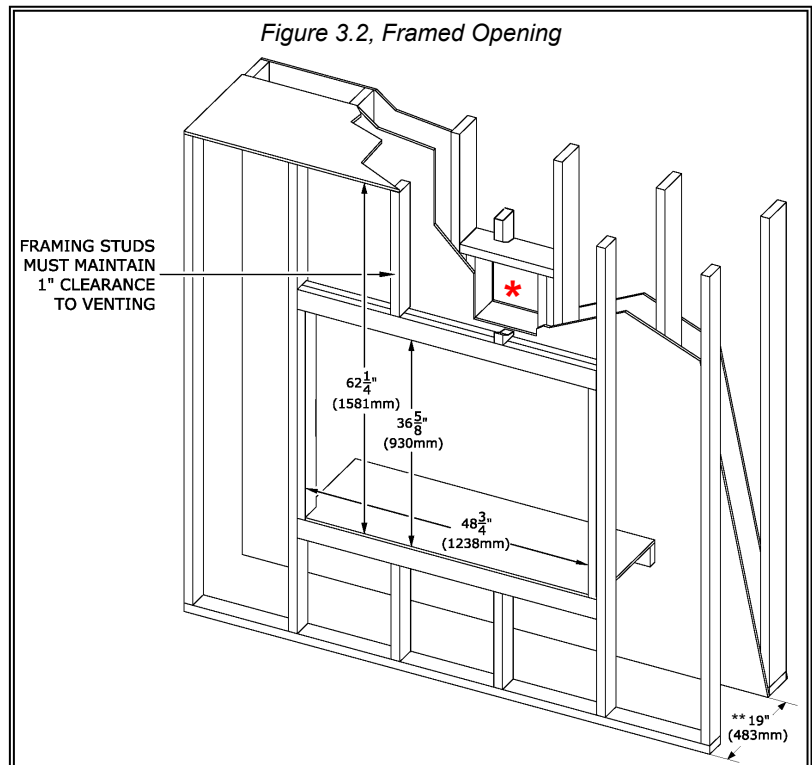

3.5 Hearth Construction and Requirements

- Determine the exact position of your fireplace, including hearth height, width, and depth. If possible, place the fireplace in such a manner that the vent termination will be placed between two studs, thus eliminating the need for additional framing.
- If masonry is to be used (optional), prepare the necessary foundation for the masonry load. When masonry construction is being used, a lintel must be used over top of fireplace to support the added weight.
- Consider the height of hearth finish material (stone, brick, etc.) when building a fireplace platform. The bottom of the fireplace must be level with finished hearth.
- Build the hearth to desired size and height. If a hearth extension is desired, combustible material may be used.

MINIMUM PLATFORM SIZE: 48-3/4 in. (1238 mm) wide x 19 in. (482 mm) deep.

WARNING
Install the fireplace on a hard metal or wood surface that extends the full width and depth of fireplace.
ABOVE FLOOR LEVEL INSTALLATIONS: A solid, continuous platform must be constructed below the appliance.
FIRE HAZARD
Do NOT install directly on carpeting, vinyl, or any combustible material other than wood.

3.6 Vent Termination Framing

IMPORTANT
Horizontal vent sections require 1/4 in. (6 mm) rise for every 12 in. (305 mm) of travel.
Vent cap location must be in compliance with the guidelines 11.3 Vent Cap Location Clearances, on page 19.

WARNING
DO NOT RECESS THE VENT CAP INTO WALL OR SIDING.

<p>Vertical Vent Terminations:</p>	<p>Follow vent pipe manufacturer’s installation instructions for vertical vent termination framing. A minimum of 1 in. (25 mm) clearance on all sides of the vertical vent pipe must be maintained.</p>
<p>Horizontal Vent Terminations:</p>	<p>Framed openings illustrated in Figures 3.3—3.5 are measured from the bottom of the fireplace enclosure floor to the center of the pipe to maintain vent system clearances. A wall thimble with a 1 in. (25 mm) clearance for all vent sides is required for all horizontal vent runs.</p>

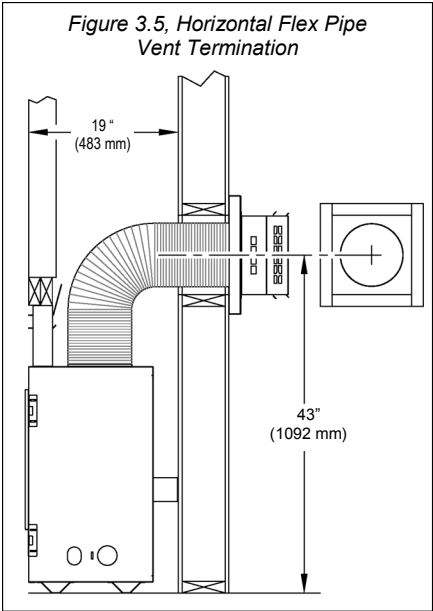
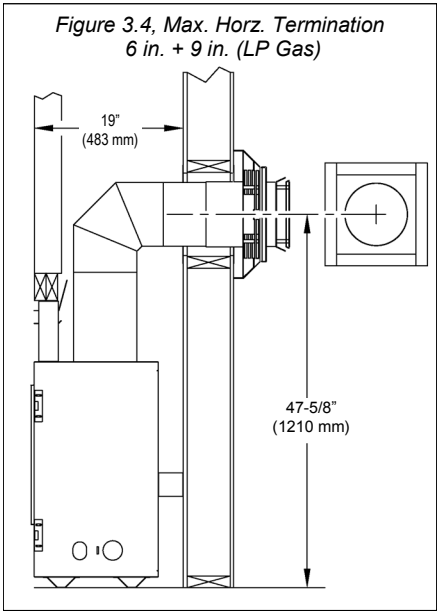
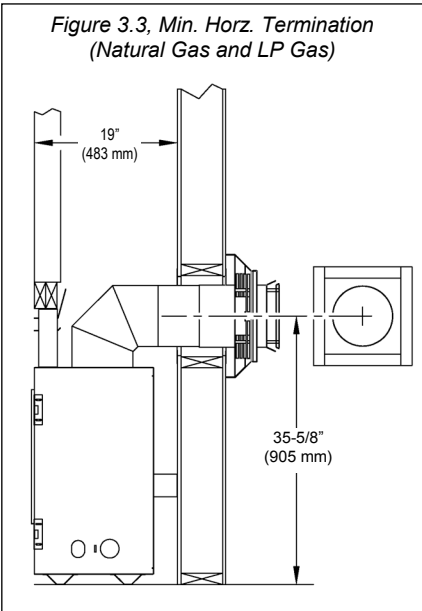

CAUTION
Cold air transfer area. The surrounding fireplace chase must comply with all clearances as outlined in this manual and be constructed in compliance with local building codes. Outside walls should be insulated to prevent cold air from entering room.

4.0 RECESS CONSTRUCTION

4.1 Television Positioning Considerations

Mounting a TV above a fireplace has become common practice. With this in mind, we conducted tests to determine possible surface temperatures reached above the fireplace.

Tests result determined surface temperatures did not exceed 150°F (66°C) when the following criteria were met:

4-1/4 in. (108 mm) deep recess constructed above the fireplace. Refer to Figure 4.2., Recess Clearances.

Mantel installed above fireplace at a minimum depth of 1 in. (25 mm) / minimum height from fireplace enclosure floor: 40 in. (1016 mm). Refer to 5.0, Mantel Projections, on page 11.

Even though temperature tests were performed, mantel depths, ceiling heights, and other factors will affect surface temperatures. Thus, we advise you to read the following paragraphs carefully before considering mounting a television above your fireplace.

Most TV manufacturers specify in their instructions that a TV should not be installed on, near, or above a heat source. Television location rests solely on the homeowner. Hussong Manufacturing shall not be held liable for any adverse effects that may be caused by heat on a TV located near a Kozy Heat fireplace.

TV operating temperatures are also affected by wall and mantle construction material. It shall be the customer's responsibility to satisfy him or herself that the preferred TV mounting and mantle design will not exceed the listed maximum operating temperature of their electronic goods.

4.2 Recess Framing and Clearances

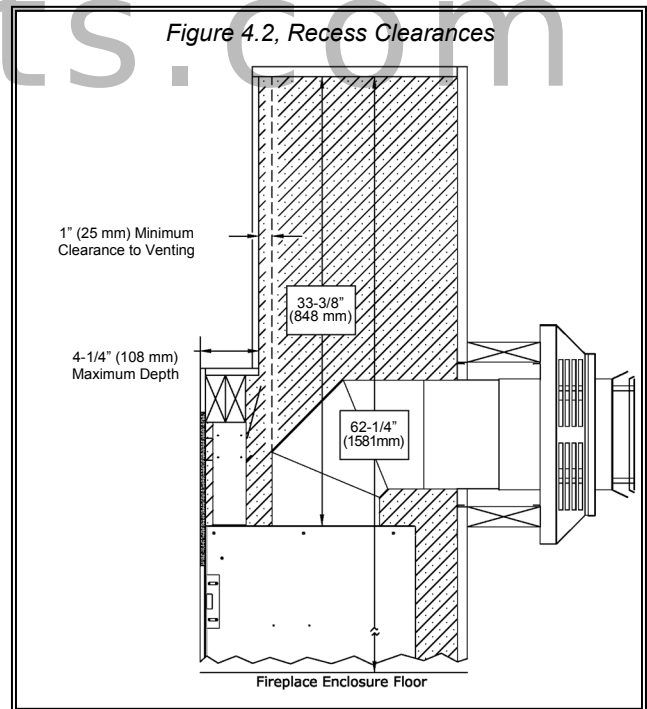
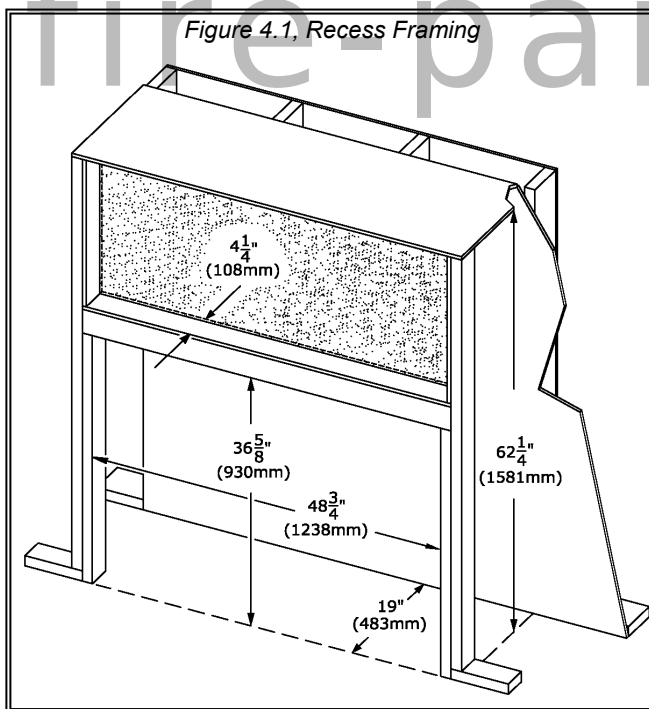

Location	Clearance
Fireplace Enclosure Ceiling to Appliance Top	33-3/8 in. (849 mm)
Fireplace Enclosure Ceiling to Fireplace Enclosure Floor	62-1/4 in. (1581 mm)
Recess Framing to Venting	1 in. (25 mm)

5.0 MANTEL REQUIREMENTS

WARNING

Non-combustible zone: No combustible materials allowed above the fireplace within shaded area for entire width and depth of the fireplace, with the exception of the header.

NOTE

If you plan to mount a television above the fireplace, refer to 4.0 Recess Construction, on page 10.

5.1 Mantel Projections

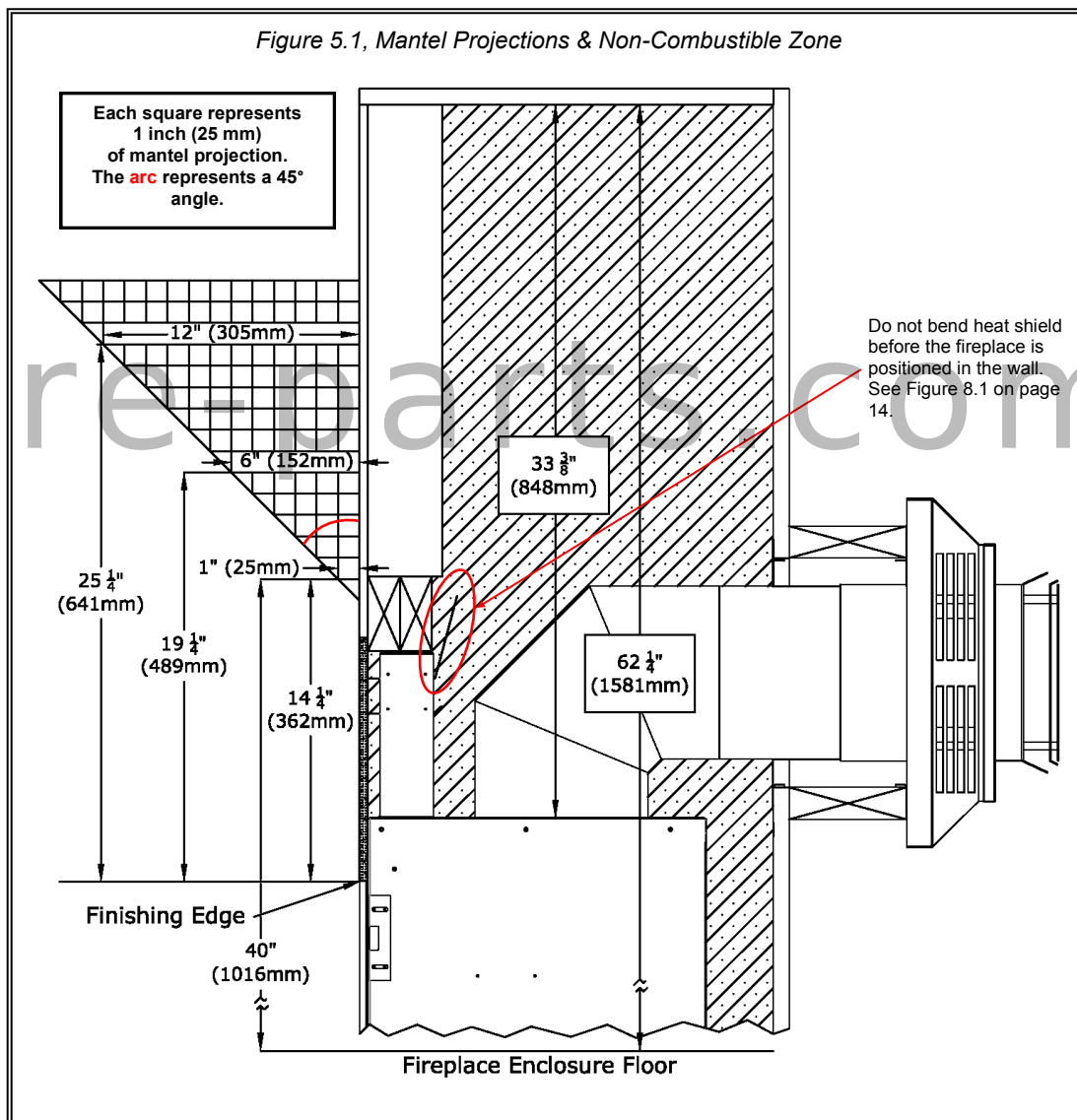
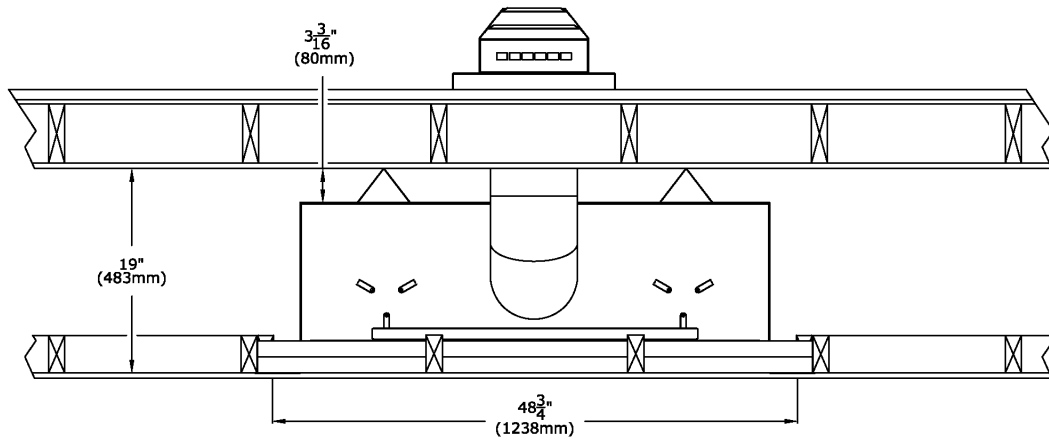

Table 5.1, Mantel Requirements

Mantel Projection	Mantel Clearance from Finishing Edge	Finishing Edge Clearance to Fireplace Enclosure Floor
1 in. (25 mm)	14-1/4 in. (362 mm)	40 in. (1016 mm)
6 in. (152 mm)	19-1/4 in. (489 mm)	45 in. (1143 mm)
12 in. (305 mm)	25-1/4 in. (641 mm)	51 in. (1295 mm)

6.0 TYPICAL FRAMING OPTIONS

6.1 Horizontal Installation



6.2 Vertical Installation

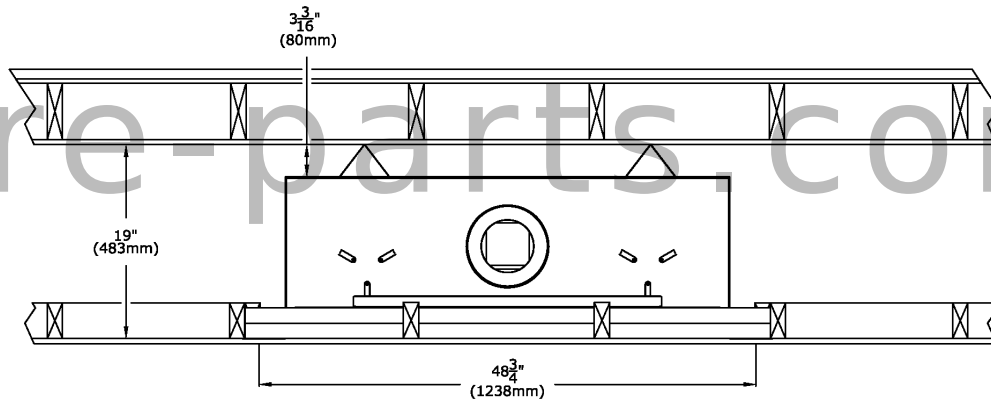

6.3 Corner Installation

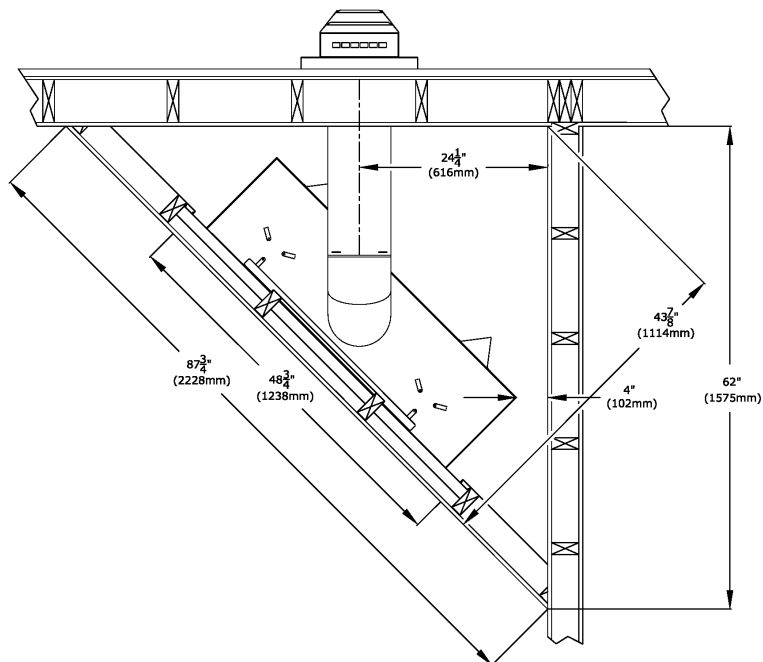

7.0 FACING AND FINISHING

This fireplace is designed to accommodate non-combustible facing material up to 1/2 in. (13 mm) thick. Install non-combustible facing material up to the facing flange (Figure 7.2) that surrounds the glass frame assembly. Do not apply any material beyond this point. The glass frame assembly must be removable.

Non-combustible material is required at the top and the sides of the fireplace. Figures 7.1 and 7.3 reflect minimum non-combustible material dimensions.

Do not secure material to lower cover panel with screws, which may damage control system components. Use a silicone sealant that has a 300°F (149°C) continuous exposure rating to secure material in this zone.

It is acceptable to pre-drill holes and to use self-tapping screws to attach non-combustible material to top and sides of fireplace face. Do not use excessively long screws.

WARNING

Maintain all minimum clearances to combustibles from the fireplace and the vent system.

Figure 7.1, Finishing Dimensions

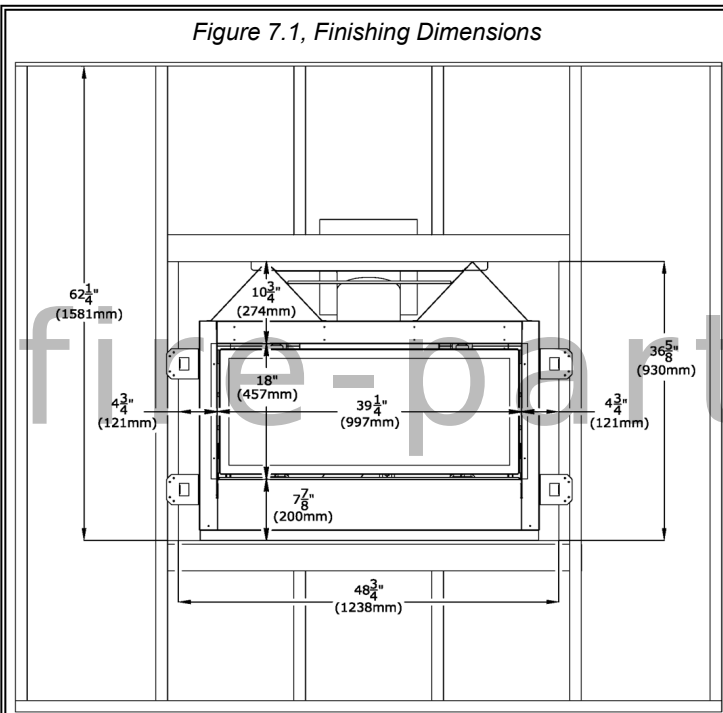

Figure 7.2, Facing Flange

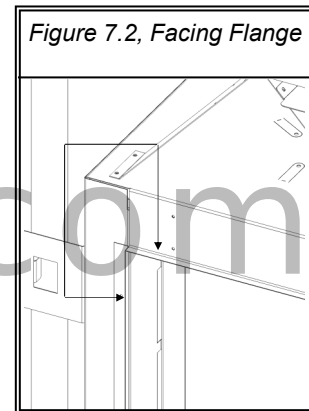



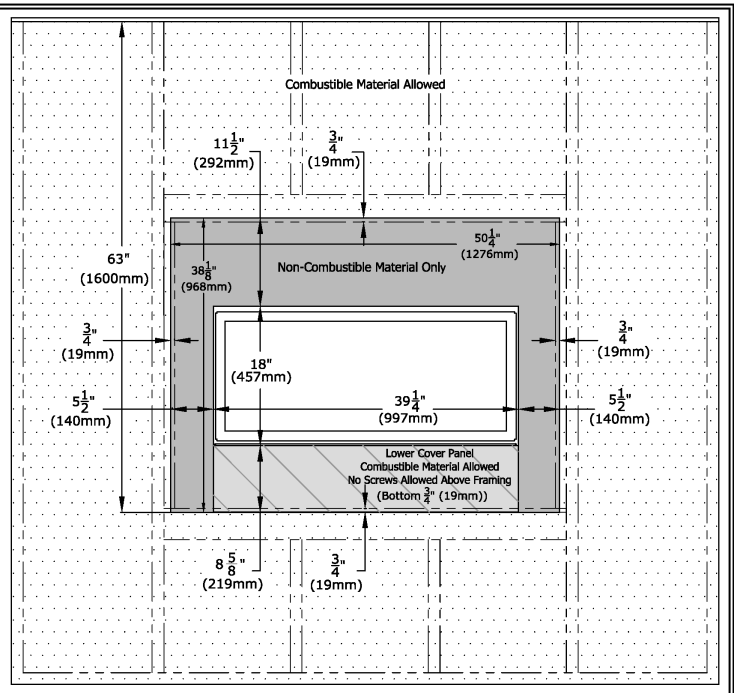

Figure 7.3, Minimum Non-Combustible Material Dimensions

-  Combustible Material Allowed
-  Combustible Material Allowed
No Screws Allowed
-  Non-Combustible Material Only



8.0

FIREPLACE PREPARATION

8.1 Stand-Off Components

WARNING

The top and the back stand-off brackets must be formed and installed prior to positioning the fireplace into a framed opening, in order to provide clearances from the appliance to combustible material.

Top stand-offs provide 7-3/4 in. (197 mm) minimum clearance to header. Use only non-combustible material in this area for the entire width of fireplace. **Do not** use wood, sheetrock, etc. in this zone. Other clearances apply. All clearances must be maintained.

Top stand-off brackets are not load bearing.

Nailing flanges include a 2-1/2 in. (64 mm) stand-off clearance to the sides of the fireplace.

8.1.1 Stand-Off Components Locations

Top stand-off brackets and stand-off heat shields are attached to the top fireplace; the back stand-offs are attached to the back of the fireplace. All stand-off components are shipped in a flat state.

8.1.2 Stand-Off Assembly and Installation

1. Remove and save the (4) screws securing the top stand-off heat shield and the top stand-off brackets. Then form each stand-off bracket as shown.
2. Re-attach the top stand-off brackets to the fireplace using screws previously removed, along with (4) screws provided in the fireplace components packet.
3. Bend stand-off heat shield as shown. Attach heat shield to the top stand-off brackets with the (4) screws provided in the fireplace components packet.
4. Attach top heat shield. **Do not bend until positioned in wall.** Once in position, hand-bend rear flange up to align with angle on top of stand-offs.

Figure 8.1, Stand-Off Assembly and Installation

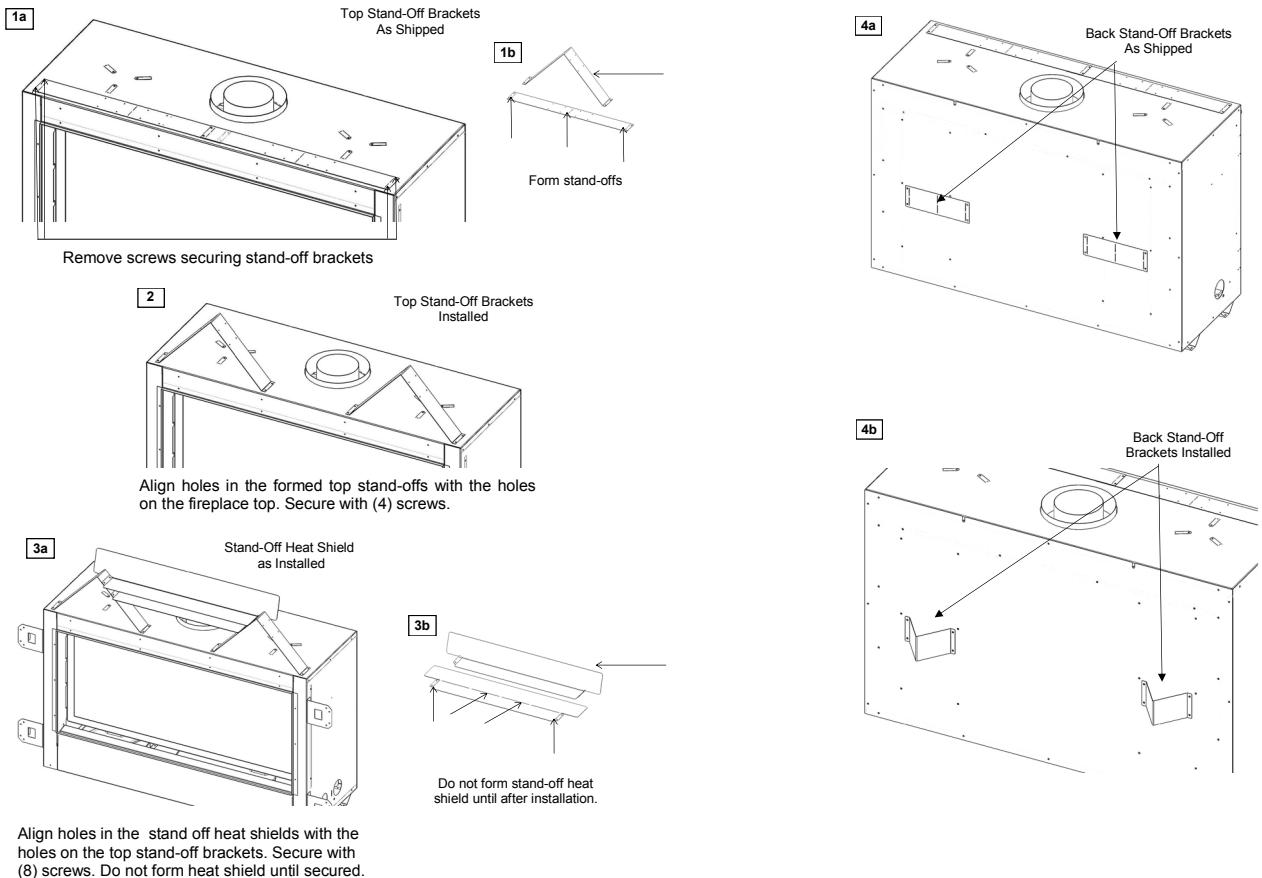

8.2 Nailing Flange Assembly and Installation

1. Remove (4) nailing flanges from the sides of the fireplace (as shipped).
2. Align the nailing flanges with the holes on outside corners of fireplace, with the stand-off flange facing away from the appliance. Secure with the screws (provided in components packet) through slots in nailing flanges.
3. Bend perforation on nailing flange until parallel with fireplace face. Do not bend toward fireplace face.
4. Position framing stud against stand-off (located on the backside of nailing flange). Secure with nails or screws.

NOTE

Depending on facing material, tabs can be adjusted forward or backward up to 1/2 in. (13 mm).

Figure 8.2, Nailing Flange Assembly and Installation

When installed, nailing flanges provide the minimum 2-1/2 in. (64 mm) clearance from the fireplace sides.

BACK VIEW

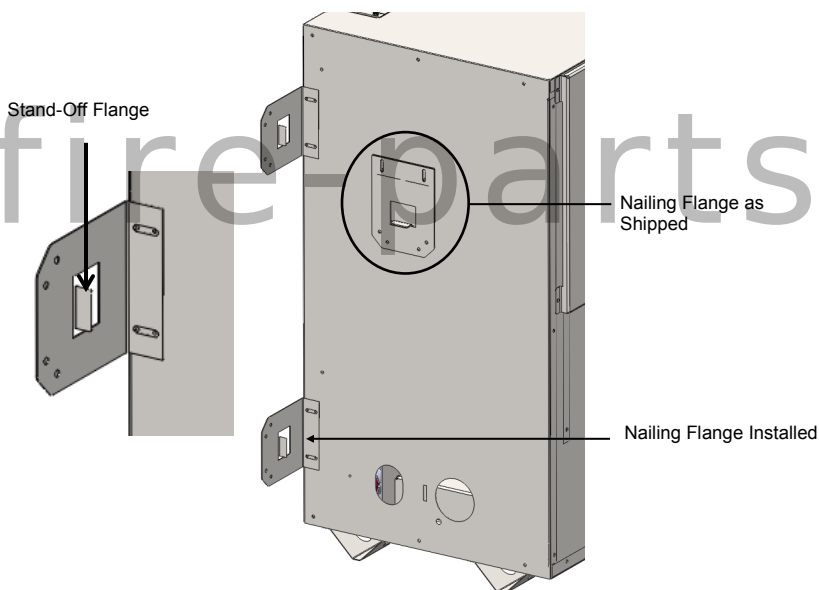

FRONT VIEW

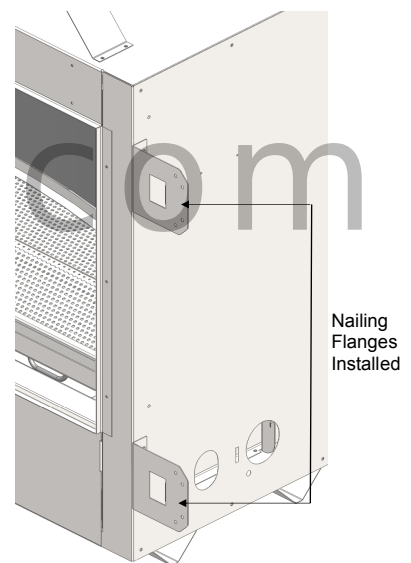

TOP VIEW

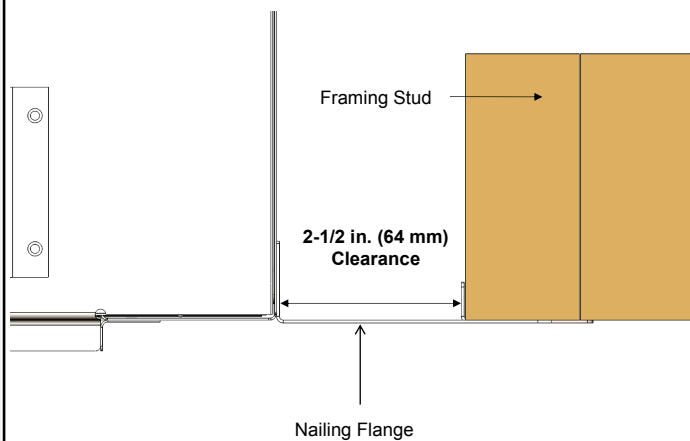

FRONT VIEW

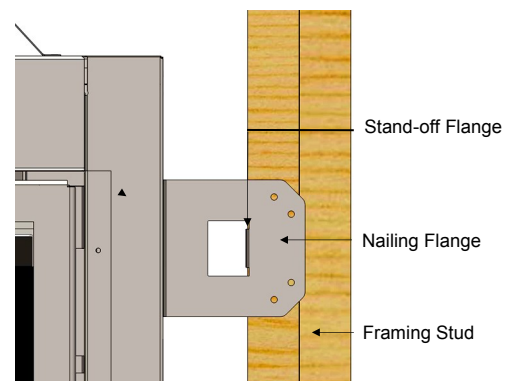

9.0 GAS LINE CONNECTION

CAUTION

Installation of the gas line must only be done by a qualified person in accordance with local building codes, if any. If not, follow ANSI Z23.1.

Commonwealth of Massachusetts: Installation must be done by a licensed plumber or gas fitter.

NOTE

A listed (and Commonwealth of Massachusetts approved) 1/2 in. (13 mm) T-handle manual shut-off valve and flexible gas connector (included) are connected to the 1/2 in. (13 mm) control valve inlet. If substituting for these components, please consult local codes for compliance.

This fireplace is equipped with a 3/8" (10 mm) x 18" (457 mm) long flexible gas connector and manual shut-off valve. The gas line should be run to the point of connection where the shut-off valve and flexible gas line will connect.

The appliance and its individual shutoff valve must be disconnected from the gas supply piping system during any pressure testing of that system at pressures in excess of 1/2 psi (3.5 kPa).

The appliance must be isolated from the gas supply piping system by closing its individual manual shut-off valve during any pressure testing of the gas line at test pressures equal to or less than 1/2 psi (3.5 kPa).

For high altitude installations, consult the local gas distributor or the authority having jurisdiction for proper rating methods.

9.1 Gas Conversion

This fireplace is manufactured for use with Natural Gas. Follow the instructions included with the conversion kit if converting to LP gas. (Sold separately)

ATTENTION

The conversion shall be carried out in accordance with the requirements of the provincial authorities having jurisdiction and in accordance with the requirements of the ANSI Z223.1 installation code.

IMPORTANT

The efficiency rating of this appliance is a product of thermal efficiency rating determined under continuous operating conditions and was determined independently of any installed system.

Table 9.1, Inlet Gas Pressures

	Natural Gas	LP Gas
Minimum Inlet Gas Pressure	5" WC (1.25 kPa) [7" WC (1.74 kPa) (recommended)]	12" WC (2.99 kPa) (recommended)
Maximum Inlet Gas Pressure	10.5" WC (2.62 kPa)	13" WC (3.24 kPa)

9.2 High Altitude Installations

ATTENTION

In the USA: The appliance may be installed at higher altitudes. Please refer to your American Gas Association guidelines which state: the sea level rated input of Gas Designed Appliances installed at elevations above 2,000 ft. (610 m) is to be reduced 4% for each 1,000 ft. (305 m) above sea level. Refer also to National Fuel Gas Code, ANSI Z223.1 / NFPA 54, local authorities, or codes which have jurisdiction in your area regarding the de-rate guidelines.

In Canada: When the appliance is installed at elevations above 4,500 ft. (1,372 m), the certified high altitude rating shall be reduced at the rate of 4% for each additional 1,000 ft. (305 m). Refer also to CSA-B149.1 Natural Gas and Propane Installation Code, Local authorities, or codes which have jurisdiction in your area regarding the de-rate guidelines.

10.0 WIRING SCHEMATICS

IMPORTANT

This system requires 120V of electricity / batteries to operate.

Using the battery back-up will operate the burner only. The fan and light components will not function on battery back-up power.

Figure 10.1, IFC Control Module Wiring

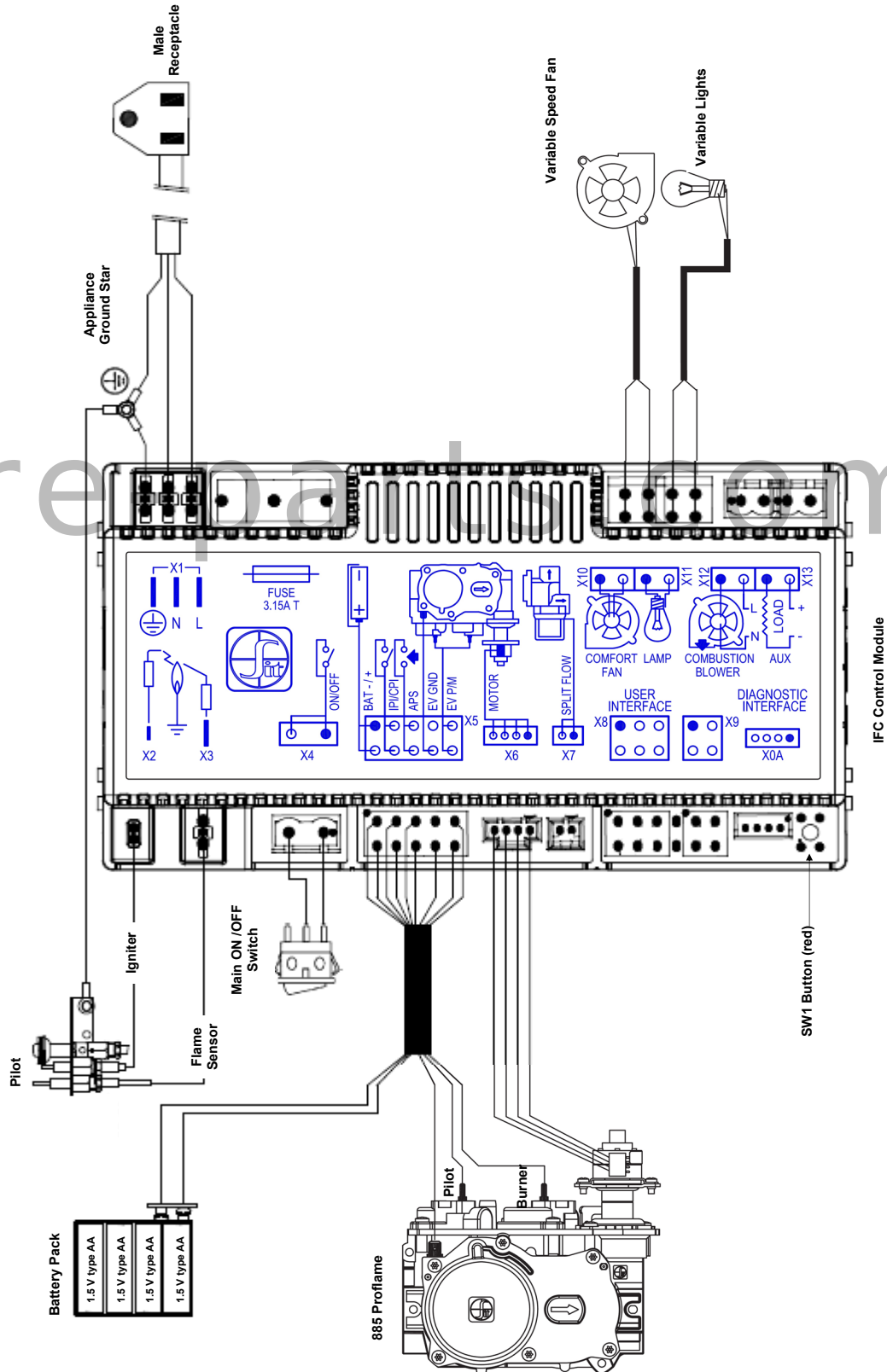

11.0 VENTING

IMPORTANT

Consult the local and national installation codes to assure adequate combustion and ventilation air is available. Flame height and appearance will vary depending upon venting configuration and the type of fuel used.

11.1 Approved Vent Systems

This fireplace is designed to be used with any of the following vent systems without the use of an additional adaptor. Refer to the vent manufacturer's installation manual for complete installation instructions. Installation must conform with venting requirements and restrictions as outlined in this manual.

Provide a means for visually checking the vent connection to the appliance after the fireplace is installed.

Table 11.1, Approved Venting

Direct Vent Chimney Systems and Reducers	Horizontal Termination	Vertical Termination
Ameri-Vent Metal 8" x 5" Direct Vent Chimney System	X	X
BDM 8" x 5" Direct Vent Chimney System	X	X
ICC EXCELDirect 8" x 5" Direct Vent Chimney System; EXCEPT TM5VT Cap	X	X
Kozy Heat #800 Series Flexible Vent System	X	
Metal Fab 8" x 5" Model DT	X	X
RLH 8" x 5" Direct Vent Chimney System		X
Security 8" x 5" Direct Vent Chimney System	X	X
Selkirk Model DT 8" x 5"	X	X
Selkirk DT 8" x 5" to 6-5/8" x 4" Reducer (used with Selkirk DT direct vent chimney system only)	X	X
Simpson Dura-Vent DV-PRO 8" x 5" direct vent systems; EXCEPT SNK14 Snorkel Cap	X	X
Simpson Dura-Vent 8" x 5" to 6-5/8" x 4" Reducer (used with Dura-Vent direct vent system only)	X	X

IMPORTANT

This fireplace requires a wall pass through thimble with a minimum of 1 in. (25 mm) clearance for all horizontal vent terminations.

NOTE

An 8" x 5" to a 6-5/8" x 4" reducer may be used for horizontal or vertical vent runs, with vent systems Dura-Vent and Selkirk.

11.2 Elbows

Maximum number of elbows for ALL vent configurations: 5

- For each additional 90° elbow used after first elbow, 3 ft. (914 mm) must be subtracted from maximum allowed venting.
- For each 45° elbow used, 1-1/2 ft. (457 mm) must be subtracted from maximum venting allowed.
- (2) 45° degree elbows may be used in place of (1) 90° elbow.

11.3 Vent Cap Location Clearances

This gas appliance must not be connected to a chimney serving any other appliance.

Location	Clearances	
	U.S.	Canada
A Above grade, veranda, porch, deck, balcony	12 in. (305 mm)	12 in. (305 mm)
B Operable window or door	9 in. (229 mm)	12 in. (305 mm)
C Permanently closed window*	12 in. (305 mm)**	12 in. (305 mm)**
D Ventilated soffit*	24 in. (610 mm)	24 in. (610 mm)
E Unventilated soffit*	12 in. (305 mm)	12 in. (305 mm)
F Outside corner*	12 in. (305 mm)	12 in. (305 mm)
G Inside corner*	6 in. (152 mm)	6 in. (152 mm)
H Meter/ Regulator	(*)	(***)
I Gas service regulator vent outlet	(*)	3 ft.
J Non-mechanical air supply inlet to building or the combustion air inlet to any other appliance	9 in. (229mm)	12 in (305mm)
K Mechanical air supply inlet	((†)(†))	6 ft. (1.83 m)
L Above paved side-walk or paved driveway located on public property ††*	(*)	7 ft. (2.13 m)
M Under veranda, porch, deck, or balcony. Must be fully opened on a minimum of two sides	12 in. (305 mm)	12 in. (305 mm)
N Between two horizontal terminations††**	12 in. (305 mm)	12 in. (305 mm)
O Between two vertical terminations	12 in. (305 mm)	12 in. (305 mm)
P Above furnace exhaust or inlet	12 in. (305 mm)	12 in. (305 mm)

* Clearance must be in accordance with local installation codes and the requirements of the gas supplier.

** Recommended to prevent condensation on window

***Not to be installed above a gas meter/regulator assembly within 3 ft. (914 mm) horizontally from the centerline of the regulator within a height of 15 ft. (4.57 m)

†† 3 ft. (914 mm) above if within 10 ft. (3.05 m) horizontally;

† Massachusetts: 10 ft. (3.05 m)

†† **NOTICE:** A vent cannot be located directly above a side-walk or paved driveway that is located between two single family dwellings and serves both dwellings.

††† Terminations may be the same height.

Figure 11.1, Vent Cap Locations

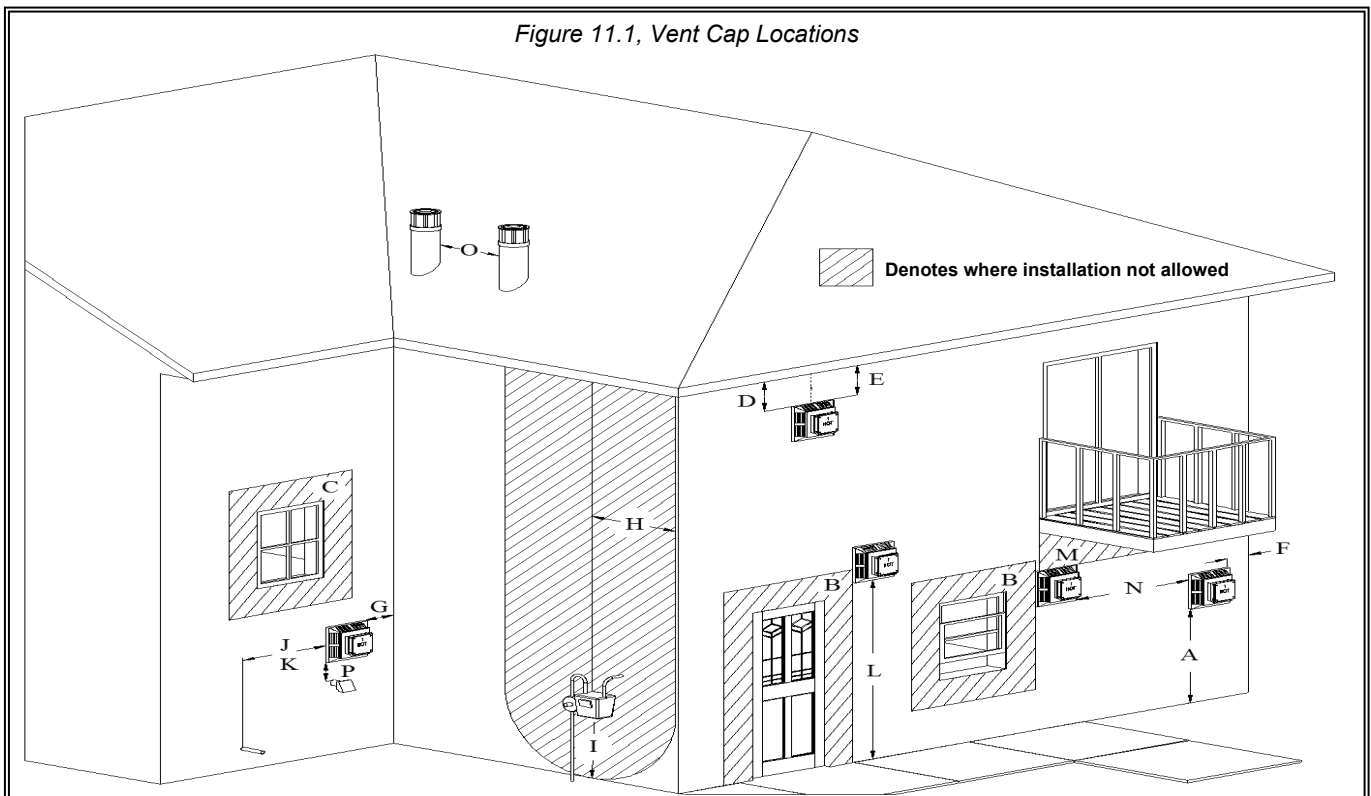

11.4 Venting for Horizontal Terminations

IMPORTANT

Horizontal vent sections require 1/4 in. (6 mm) rise for every 12 in. (305 mm) of travel.

11.4.1 Vent System Clearances

Table 11.2, All Approved Horizontal Vent Systems, Clearances to Combustible Material

Vent Pipe Clearances	Top	Bottom	Sides
	1 in. (25 mm)	1 in. (25 mm)	1 in. (25 mm)

11.4.2 Horizontal Termination 8" x 5" Vent Configurations

Natural Gas

Minimum	90° elbow	+	9 in. (229 mm) horizontal run	+	Termination cap
Maximum	90° elbow	+	4 ft. (1.22 m) horizontal run	+	Termination cap

LP Gas

Minimum	90° elbow	+	9 in. (229 mm) horizontal run	+	Termination cap		
Maximum	A 6 in. (153 mm) vertical pipe with a 9 in. (229 mm) vertical pipe	+	90° elbow	+	4 ft. (1.22 m) horizontal run	+	Termination cap

11.4.3 Horizontal Termination 6-5/8" x 4" Reducer Vent Configurations

Natural Gas and LP Gas

Minimum	6-5/8" x 4" Reducer	+	12 in. (305 mm) vertical length	+	90° elbow	+	9 in. (229 mm) horizontal run	+	Termination cap
Maximum	6-5/8" x 4" Reducer	+	12 in. (305 mm) vertical length	+	90° elbow	+	3 ft. (914 mm) horizontal run	+	Termination cap

Figure 11.2, Appliance shown with 8" x 5" Minimum Horizontal Termination Vent Configuration

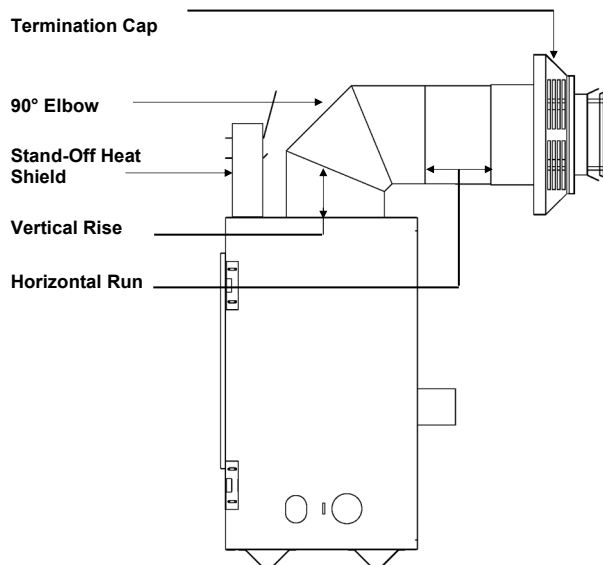
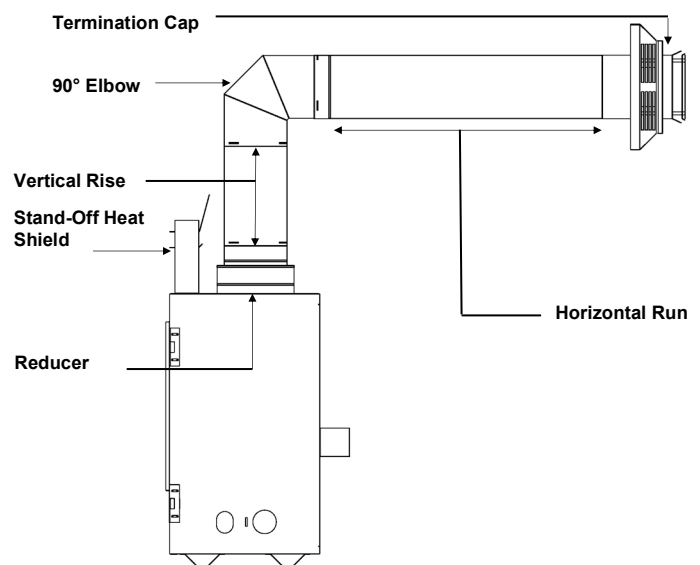

Figure 11.3, Appliance shown with 6-5/8" x 4" Reducer Minimum Horizontal Termination Vent Configuration



IMPORTANT

Flame height and appearance will vary depending upon vent configuration and type of fuel used.

11.5 Venting for Vertical Terminations

11.5.1 Vertical Pipe Clearances

Table 11.3, All Approved Vertical Venting Systems, Clearances to Combustible Material

Vent Pipe Clearances	Top	Bottom	Sides
	1 in. (25 mm)	1 in. (25 mm)	1 in. (25 mm)

11.5.2 Vertical Termination 8" x 5" Vent Configurations

Natural Gas and LP Gas

Minimum	2 ft. (610 mm) vertical length	+	Termination cap
Maximum	50 ft. (15.24 m)** vertical length	+	Termination cap

**A restrictor is recommended for 30 ft. (9.14 m) to 50 ft. (15.24 m) of venting for vertical terminations if no elbows are used.

11.5.3 Vertical Termination 6-5/8" x 4" Reducer Vent Configurations

Natural Gas and LP Gas

Minimum	6-5/8" x 4" Reducer	+	2 ft. (610 mm) vertical length	+	Termination cap
Maximum	6-5/8" x 4" Reducer	+	50 ft. (15.24 m)** vertical length	+	Termination cap

**A restrictor is recommended for 30 ft. (9.14 m) to 50 ft. (15.24 m) of venting for vertical terminations if no elbows are used.

Figure 11.4, Appliance shown with 8" x 5" Minimum Vertical Termination Vent Configuration

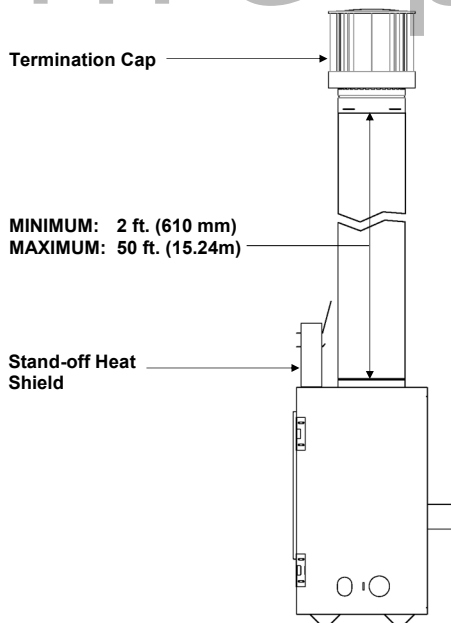
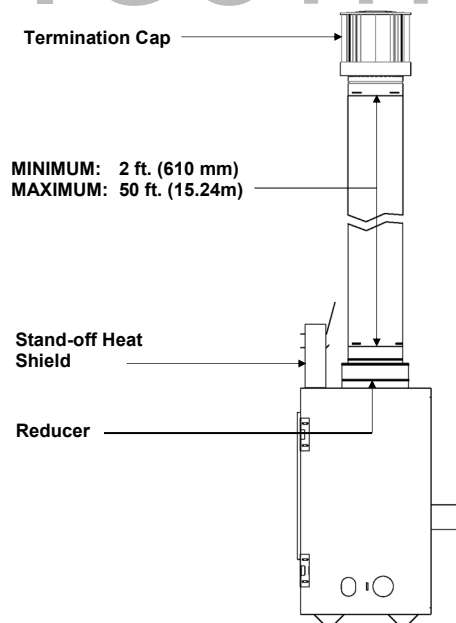

Figure 11.5, Appliance shown with 6-5/8" x 4" Reducer Minimum Vertical Termination Vent Configuration



11.6 Restrictor Assembly and Installation

Each installation is unique and affected by various factors including venting configuration, altitude and climate. Therefore, after fireplace installation is complete, a restrictor (included with fireplace components packet) may be required or may need to be removed or modified.

Please refer to Figure 11.6 on page 22 for installation instructions if installing the restrictor in conjunction with venting. A restrictor may be used to achieve desired flame appearance on any venting configuration with 6 feet (1.83 m) of vertical pipe or more.

18.3 Restrictors, on page 42, outlines restrictor recommendations depending on burner flame appearance and instructions on installation after venting is completed.

Figure 11.6, Restrictor Assembly and Installation

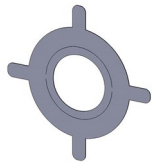

Restrictor

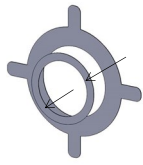

When needed, remove circle to create less restriction

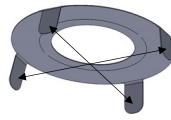

Bend tabs to approx. 80° angles to create tension to hold itself in place when installed.

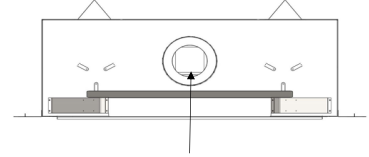

Slide restrictor into exhaust pipe on top of fireplace with tabs pointing towards you prior to attaching venting.

11.7 Horizontal and Vertical 8" x 5" Combination Venting

NOTE

11.6, Restrictor Assembly and Installation, on pages 21 and 22, has information on restrictor installation in conjunction with venting installation. 18.3, Restrictors, on page 42, has information on restrictor recommendations depending on burner flame appearance, and instructions on installation after venting is completed.

CAUTION

This gas appliance must not be connected to or joined with any other chimney flue serving another appliance.

Figure 11.7, Natural Gas Combination Venting Using 8" x 5" Pipe

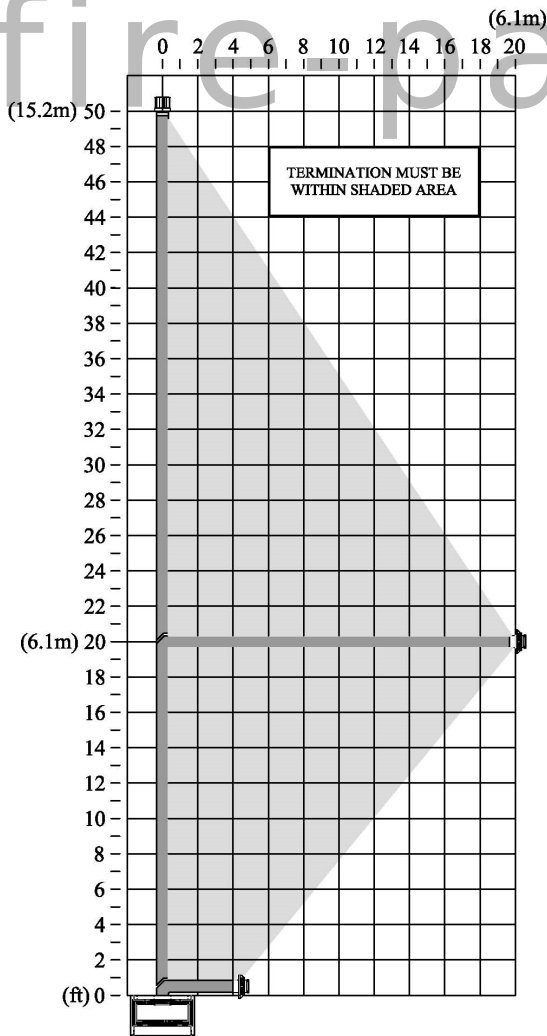

MAXIMUM: 20ft. (6.1m) Horizontal / 20ft. (6.1m) Vertical

Figure 11.8, LP Gas Combination Venting Using 8" x 5" Pipe

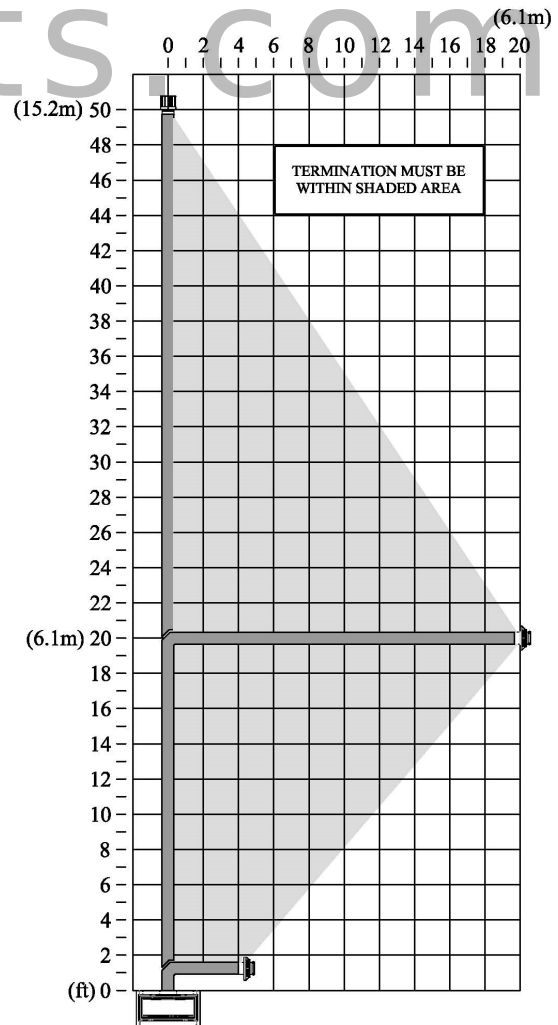

MAXIMUM: 20ft. (6.1m) Horizontal / 20ft. (6.1m) Vertical

11.8 Horizontal and Vertical 6-5/8" x 4" Reducer Combination Venting

NOTE

11.6, Restrictor Assembly and Installation, on pages 20 and 21, has information on restrictor installation in conjunction with venting installation. 18.3, Restrictors, on page 42, has information on restrictor recommendations depending on burner flame appearance, and instructions on installation after venting is completed.

CAUTION

This gas appliance must not be connected to or joined with any other chimney flue serving another appliance.

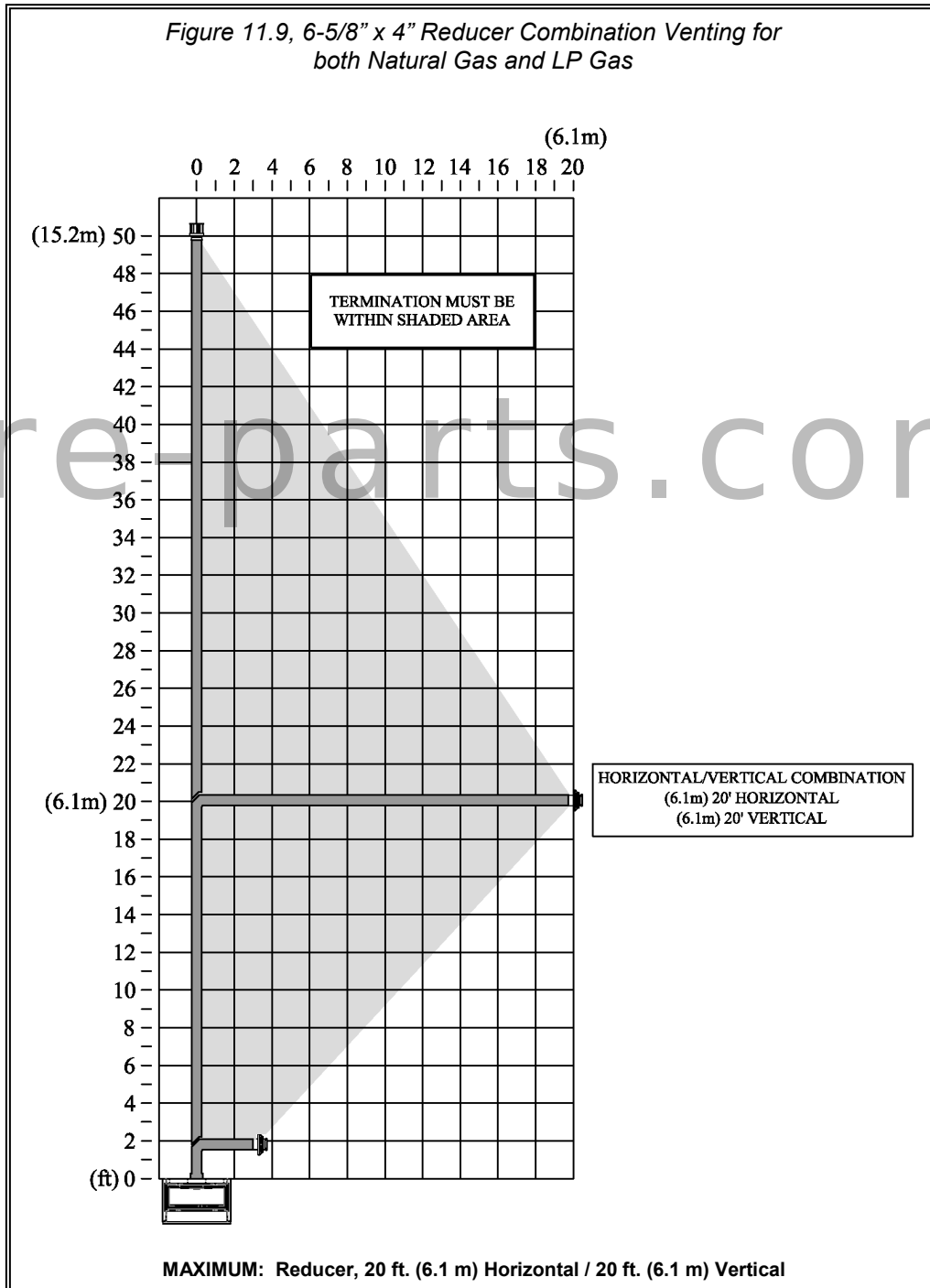

11.9 #800-1 Series Direct Vent Termination Kit(s)

IMPORTANT

The flex pipe is permanently attached to the exterior plate. **DO NOT ATTACH** either #844-1 or #845-1 termination kit to fireplace (or extension kit) until it has passed through the wall. Install termination plates to the outside wall exterior.

- If terminating against vinyl siding, a vinyl siding protector must be used (included with the #844-1 and #845-1 direct vent kits). Follow instructions included. (Not shown in Figure 11.10)
- Each #846-1 extension kit contains enough 5" & 8" flexible aluminum pipe to extend chimney an additional 6 ft. (1.83 m).
- 11.6, Restrictor Assembly and Installation, on pages 21-22 has information on restrictor installation in conjunction with venting installation. 18.3, Restrictors, on page 42 has information on restrictor recommendations depending on burner flame appearance and instructions on installation after venting is completed.
- Refer to Figure 11.10, Assembly and Installation of #800-1 Series.

11.9.1 Assembly and Installation

1. Mount the required #800 WPT-3 wall pass-through thimble (G) (minimum 1 in. [25 mm] clearance) to the exterior wall and seal.
2. Apply a liberal bead of exterior sealant around outer edge of termination box (A), placing assembly through the wall thimble in exterior wall. Place screws through the four holes (B), securing it in place.
3. Form the 5" & 8" flexible aluminum pipes on termination kit (#844-1 or #845-1), and if applicable, on each extension kit, as shown in Figure 11.10. Then, gently pull 5" & 8" pipes down to the top of the fireplace, or if applicable, the extension kit.
IMPORTANT: DO NOT stretch extension kit beyond 6 ft. (1.83 m); DO NOT stretch beyond what is required. It is very difficult to recompress flex pipes once stretched.
4. Place a bead of sealant outside 5" flex pipe collar (C) (end with EXTERNAL LIP) and sliding it into 5" pipe on extension kit or top of fireplace (D). Secure with 3 evenly spaced screws.
5. Place a bead of sealant inside 8" flex pipe collar (E) (end with the INTERNAL lip), sliding it over 8" pipe on top of fireplace (F). Secure with 3 evenly spaced screws.
6. If additional extension kits are required, repeat Steps 3 and 4, placing 5" & 8" pipes onto previous extension kit.

Figure 11.10, Assembly and Installation of #800-1 Series

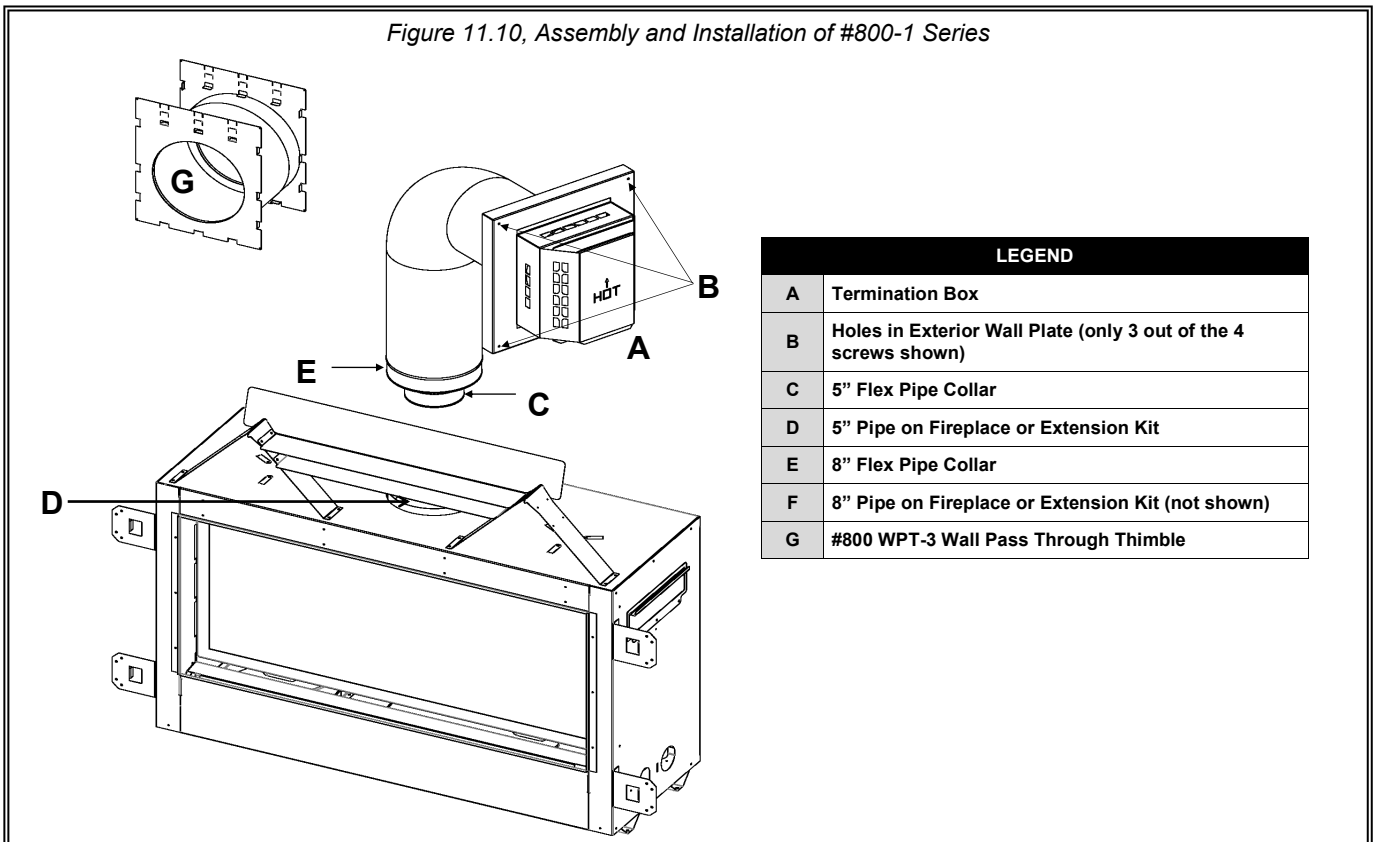

11.10 Vertical Vent Termination Clearances

Roof Pitch	Minimum Height (H)	
	Feet	Meters
Flat to 6/12	1.0	0.30
Over 6/12 to 7/12	1.25	0.38
Over 7/12 to 8/12	1.5	0.46
Over 8/12 to 9/12	2.0	0.61
Over 9/12 to 10/12	2.5	0.76
Over 10/12 to 11/12	3.25	0.99
Over 11/12 to 12/12	4.0	1.22
Over 12/12 to 14/12	5.0	1.52
Over 14/12 to 16/12	6.0	1.83
Over 16/12 to 18/12	7.0	2.13
Over 18/12 to 20/12	7.5	2.27
Over 20/12 to 21/12	8.0	2.44

CAUTION

This appliance must not be connected to or joined with any chimney flue serving any other appliance.

Figure 11.11, Vertical Vent Termination Clearances

H - Minimum height from roof to lowest discharge opening

*If vent is closer than 18 in. (457 mm), it must terminate at least 2 ft. (0.61 m) higher than any portion of a building within 10ft. (3.05 m) of the vent.

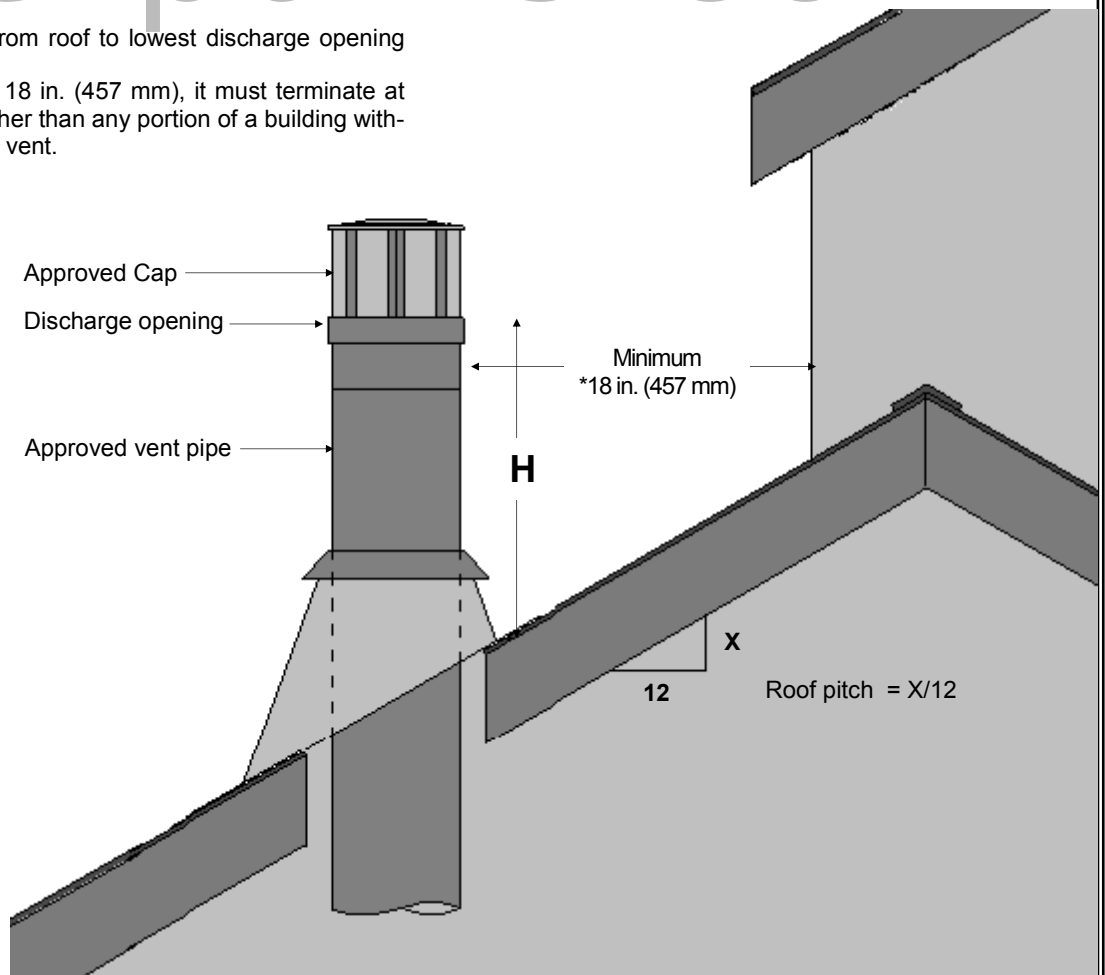

12.0 #970 HEAT DUCT KIT

CAUTION

Read and follow instructions carefully prior to and during installation of this optional heat duct kit.

WARNING

INSTALLATION OF THIS DUCT KIT & ELECTRICAL WIRING MUST BE PERFORMED BY A QUALIFIED SERVICE PERSON. INSTALLATION MUST BE IN ACCORDANCE WITH LOCAL CODES, OR IN THE ABSENCE OF LOCAL CODES, WITH THE NATIONAL ELECTRICAL CODE, ANSI/NFPA 70, OR THE CANADIAN ELECTRICAL CODE, CSA C22.1.

DO NOT SUBSTITUTE THE FLEXIBLE HEAT DUCT PIPE WITH PLASTIC VENT PIPE.

This kit includes:

- | | |
|--|-----------------------------|
| (1) 6 in. (152 mm) diameter flexible heat duct pipe, expandable to 20 ft. (6.10 m) | (2) Mounting bracket screws |
| (1) Register mounting frame with collar | (11) Sheet metal screws |
| (1) Register cover with screws | (4) Sheet rock screws |
| (1) Duct collar | (3) Flange nuts |
| (1) Fan assembly | (1) Strapping cord |
| (1) Fan housing cover plate | (3) Wire nuts |
| (1) Speed control mounting bracket | (2) Fan wire connectors |
| (1) Speed Control | |

NOTE: A junction box, cover, and hardware must be purchased to mount the speed control.

12.1 Specifications

Clearance to combustibles: 0 in. (0 mm)

Clearance from air duct to ceiling: 2 in. (51 mm)

Minimum vent run: 2 ft. (609 mm)

Maximum vent run: 20 ft. (6.10 m) in any direction, including downward.

The fireplace is manufactured with (2) heat duct knock-outs. One, or both, may be utilized.

The register mounting frame is designed to fit between 2" x 4" stud walls, 16 in. (406mm) on center.

An oval duct pipe (equivalent to 6 in. [152 mm] round) can be used in conjunction with the included 6 in. (152 mm) diameter flexible heat duct pipe, included with this kit. It must be purchased from a HVAC supplier.

Carefully plan location of duct pipe runs and register in relation to fireplace.

Figure 12.1, Possible Heat Duct Locations

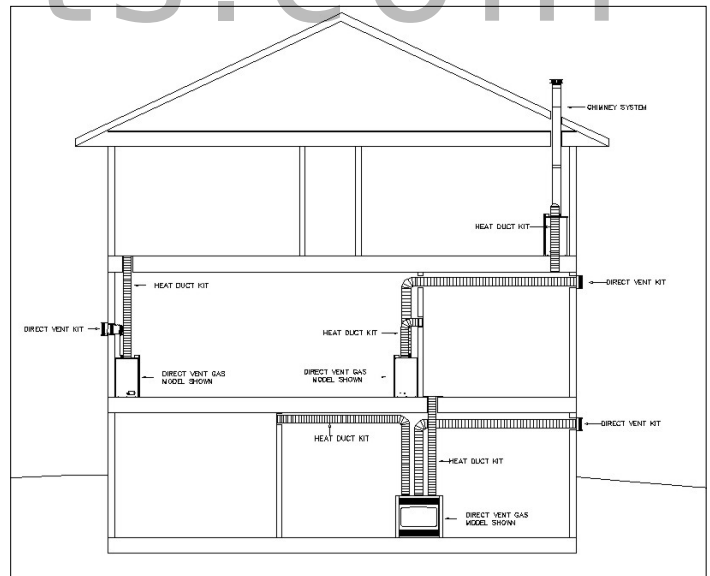

12.2 Attach Heat Duct to Fireplace

1. Bend the tabs on fireplace top up. With circulation holes facing downward, use (3) screws to fasten the tabs to the duct collar.
2. Secure duct pipe to collar. Confirm that the screws penetrate both the duct pipe and the collar. Do not cover circulation holes on the duct collar.
3. Position the fireplace in the desired location.

Figure 12.2, Attached Heat Duct



12.3 Install Register Mounting Frame and Junction Box

The register mounting frame and the fan housing are designed to fit between 2" x 4" stud walls, 16 in. (406mm) on center. Additional framing is required if larger opening exists.

NOTE

The fan motor on the heat duct kit may be on opposite side of fan shown in photos. The romex connector and grounding screw are located on the motor side of the bracket.

1. Locate and mark the position of the register.
2. Insert the register mounting bracket into the 16 in. (406 mm) opening.
 - A. Level and adjust the mounting bracket. The sides of the mounting bracket shall be flush with front of studs; the front of mounting bracket shall protrude 1/2 in. (13 mm) in front of the studs. This allows enough room for 1/2 in. sheetrock installation.
 - B. Secure the mounting bracket to framing with the provided (4) sheetrock screws.
3. Install the junction box on the wall at desired location. The junction box is used to house the speed control assembly, which controls fan speed and operation.

Figure 12.3, Register Mounting Frame

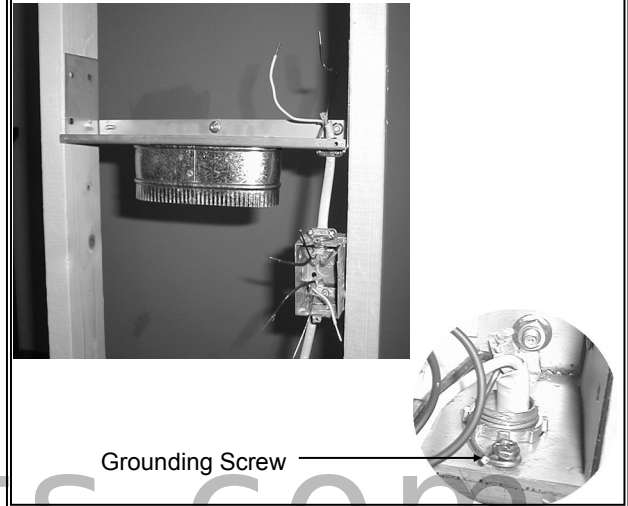

12.4 Install and Wire Fan Assembly

1. Attach, but do not tighten, flange nuts to the mounting studs on the back of the register mounting bracket.
2. Align (3) slots on the fan assembly to studs, then slide the fan into position. Tighten the flange nuts to secure.
3. Slide the included fan wire connectors into the fan terminals.
4. Properly wire the 110 VAC wire to the hot and neutral fan wires, and the speed control wires, with provided wire nuts. Run 110 VAC to fan speed control, then from the fan speed control through the romex connector (on the register bracket). Secure grounding wire to the grounding screw installed in register mounting bracket.

Figure 12.4, Installed Fan Assembly

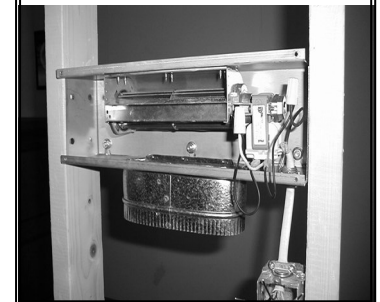

IMPORTANT

Fan must be properly grounded. Use provided grounding screw to secure grounding wire to the register mounting bracket.

Figure 12.5, Fan Wiring

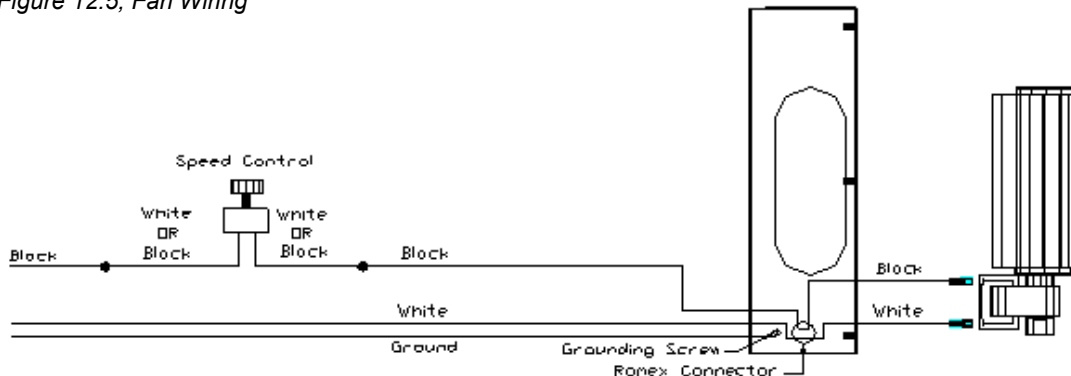

12.5 Run and Secure Duct Pipe

1. Run the duct pipe to the register location.
2. If an oval pipe is to be used in conjunction with the 6 in. (152 mm) round duct pipe,
 - A. Shape the 6 in. (152 mm) round duct pipe to fit **outside** the oval duct pipe. Secure with the screws provided.
 - B. Slide the oval duct pipe over the oval collar on the register mounting bracket. Secure with the sheet metal screws provided.OPTIONAL: Secure duct pipe with any additional screws provided.
3. If an oval duct pipe is not used,
 - A. Shape the 6 in. (152 mm) round duct pipe so it will fit **outside** the oval collar on the register mounting bracket.
 - B. Slide the round duct pipe until it touches the register mounting bracket.
 - C. Position the locking strap around the 6 in. (152 mm) duct pipe, above the crimped metal.
 - D. Pull the locking strap tight enough to firmly secure the duct pipe.

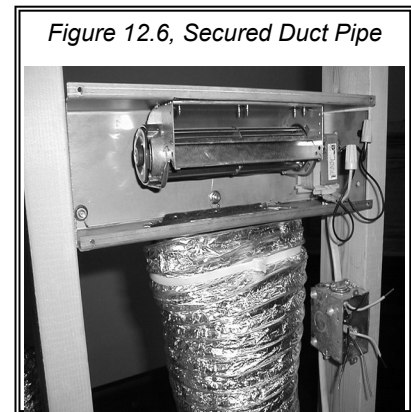

12.6 Complete the Installation

1. Install sheetrock or wall finish material as desired before attaching the register cover and fan housing cover plate.
2. Position the cut-out portion of the fan housing cover plate over the fan chute to allow air flow. Align the holes in the fan housing cover plate to the corresponding holes in the register mounting plate and fan assembly. Secure with (4) screws provided.
3. Slide the speed control through the mounting bracket. Secure with the mounting nut.
4. Secure mounting bracket to the junction box with the (2) screws provided.
5. Center the register cover over the fan housing cover plate to install. Secure register cover to stud wall with the provided mounting screws.
6. Attach a cover plate (not provided), then install the control knob for the speed control.
7. Complete the fireplace installation by following the instructions included with the fireplace.

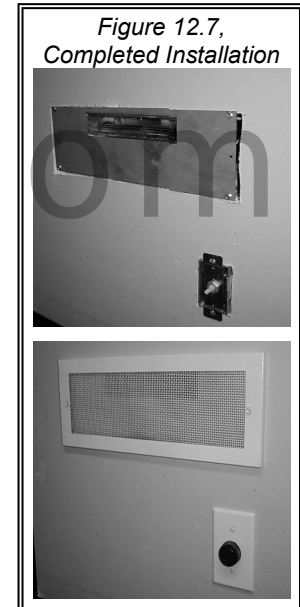

12.7 Operating Instructions

1. After complete fireplace installation and subsequent initial burn period, turn the fireplace burner ON by following the lighting instructions included with the fireplace.
2. Allow the fireplace to produce heat for approximately 15 minutes.
3. To operate the heat duct fan, turn the wall-mounted speed control *clockwise* until it stops. The fan should turn on and be operating at its highest speed. Adjust the speed to desired air flow level by turning the speed control knob *counter-clockwise* until it 'clicks' off.

12.8 Maintenance

The duct register must be kept clear and unobstructed. Clean and vacuum as necessary to remove dust, lint, etc. from fan which will inhibit air flow.

Detach the register cover and the fan housing cover plate at least once a year to remove dust, lint, etc. from the fan. More frequent cleaning may be necessary.

The fireplace must be maintained and serviced as outlined in the unit installation and operating instructions.

13.0 FIREPLACE SETUP

13.1 Glass Frame Assembly

WARNING

DO NOT OPERATE THIS FIREPLACE WITH THE GLASS FRONT REMOVED, CRACKED OR BROKEN. REPLACEMENT OF THE GLASS SHALL BE DONE BY A LICENSED OR QUALIFIED SERVICE PERSON.

13.1.1 Remove Glass Frame Assembly

1. Open the valve access cover by lifting the front up, and rotating it towards the glass frame.
2. Using a phillips head screwdriver, remove screws securing valve access cover (1 ea. side).
3. Loosen, but do not remove (2) wing nuts securing component upper heat shield. Pull component board forward (secured to heat shield with magnet). Remove heat shield.
4. Locate (2) spring loaded handles at bottom of firebox. Pull handles out and down to release.
5. Lift glass frame assembly up and off (2) tabs at top of firebox.

13.1.2 Install Glass Frame Assembly

1. Place glass frame assembly top over tabs at top of firebox.
2. Pull bottom handles out and up to secure assembly bottom.
3. Reinstall component upper heat shield, secure with wing nuts, re-attach component board magnet to upper heat shield.
4. Reinstall valve access cover, using screws previously removed.

Figure 13.1, Glass Frame Assembly Removal and Installation

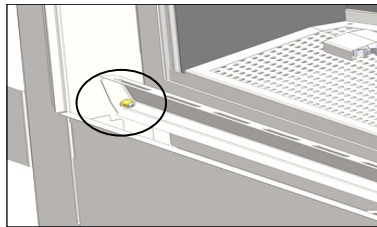

Screws securing valve access cover (1 ea. side)

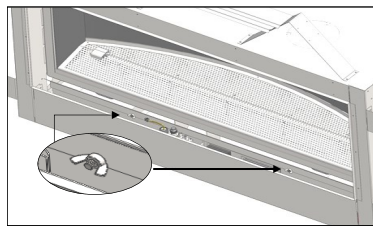

Wing nuts securing component upper heat shield

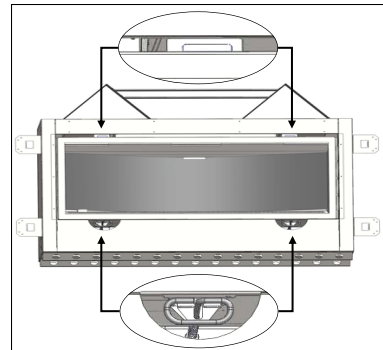

13.2 Safety Barrier Installation

WARNING

A barrier designed to reduce the risk of burns from the hot viewing glass is provided with this appliance and shall be installed.

NOTE

Please refer to Figure 13.2 for barrier dimensions before installing facing material. The gray, shaded lines represent the fireplace in relation to the dimensions of the safety barrier.

- All safety barriers require a 1/4 in. (6 mm) minimum top clearance to allow barrier mounting and removal.
- All safety barriers shown allow a combination of finishing material to 1-3/8 in. (35 mm) thick, measured from the fireplace.

13.2.1 Installation Instructions

1. Center the screen front over the glass frame assembly, allowing the screen front's mounting to fit inside the air openings.
 2. Align the mounting brackets (located on the back) with the slots in the fireplace. Raise slightly and push back to desired position.
 3. Lower the screen front until the notched tabs are firmly in position. To remove, lift up and out of slots.
- Safety screens are available in various colors. See dealer for details.

Figure 13.2, Safety Barrier Dimensions

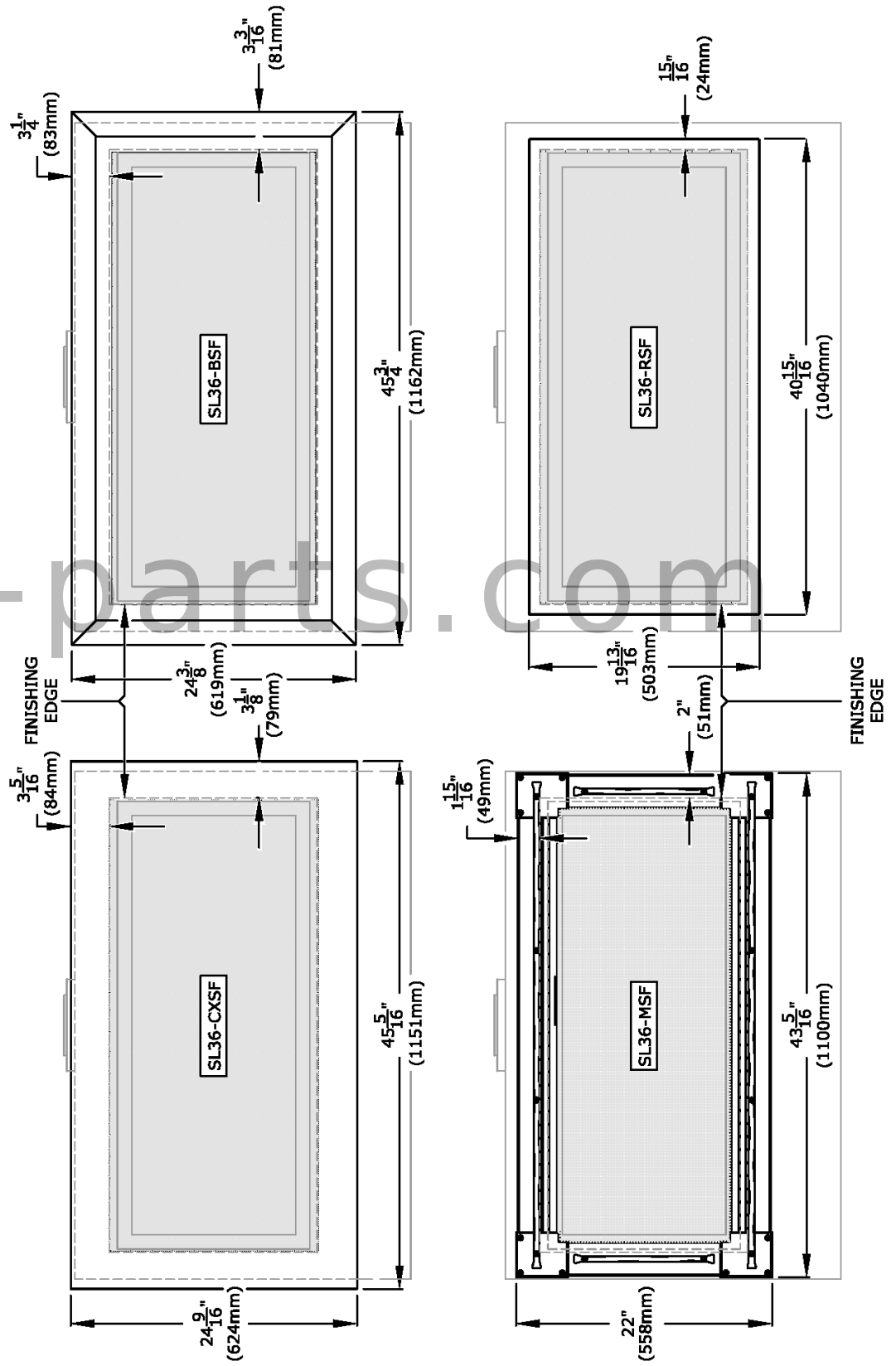

13.3 Light Kit

NOTE

To avoid damage and prolong the life of halogen bulbs, never touch with bare hands. Always use a soft cloth when handling.

CAUTION

Disconnect all electric power from fireplace before performing this task.

ATTENTION

If converting to LP (propane) gas, do so now before installing light kit components. Follow instructions provided with the conversion kit (sold separately).

13.3.1 Install Light Kit

1. Remove glass valance assembly. Refer to 13.1 Glass Frame Assembly, on page 29.
2. Remove (10) screws securing burner cover, then lift the cover out of the firebox.
3. Install (6) halogen bulbs (included in components packet) into lamp bases.
4. Reinstall burner cover, securing with screws previously removed.

Figure 13.3, Screw Location on Burner Cover

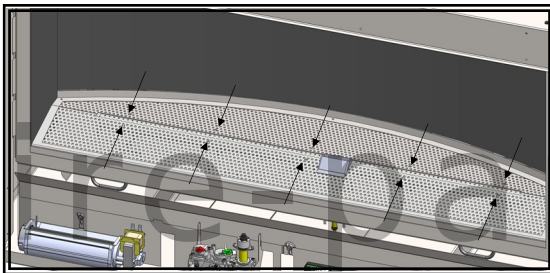
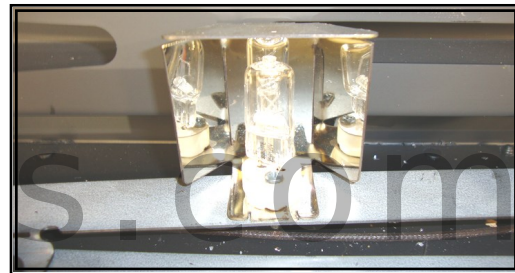

Figure 13.4, Halogen Bulb Installed



13.4 Glass Media

IMPORTANT

Use **ONLY** #109 Series Glass Media (9 lbs. / 4.08 kg) in this fireplace. **DO NOT** substitute materials, or use more than specified. Glass media must be one layer deep across the entire burner area to avoid possible delayed ignition / sooting issues.

13.4.1 Install Glass Media

WARNING

DO NOT BLOCK PILOT ASSEMBLY WITH GLASS MEDIA; A BLOCKED PILOT MAY CAUSE DELAYED IGNITION!

Figure 13.5, Glass Media Installation

Install glass media onto burner assembly and pilot shield, being careful not to block pilot assembly.

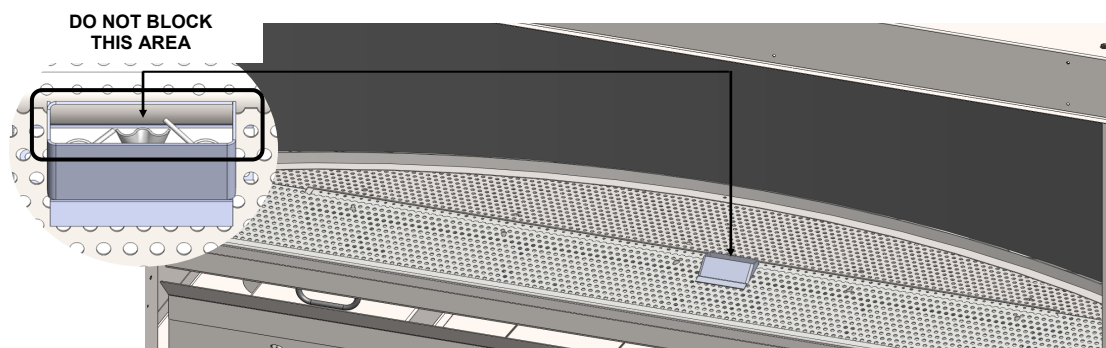

13.5 Control Board

CAUTION

If burner and/or pilot have been burning, use appropriate protection to avoid burns or damage to personal property before removing any components.

WARNING

DO NOT OPERATE THIS FIREPLACE WITHOUT SEALING GASKET (LOCATED UNDER THE CONTROL BOARD) IN PLACE. IF GASKETING IS DAMAGED, IT MUST BE REPLACED.

13.5.1 Control Board Removal

1. Shut off main gas line to appliance.
2. Remove glass frame assembly.
3. Disconnect gas line flex tube from manual shut-off on the valve.
4. Unplug all components from receptacle, disconnect all wiring harnesses attached to gas valve.
5. Remove glass media.
6. Remove burner cover (secured with [10] screws).
7. Remove burner venturi housing. Remove burner tube from mounting cradles.
8. Remove (2) nuts securing light bar to control board, carefully move light bar backwards far enough to clear board.
9. Remove (8) screws securing control board, lift board out of firebox being careful not to damage sealing gasket lying underneath.

13.5.2 Control Board Installation

1. Place control board in firebox, aligning holes in board to holes in firebox bottom. **MAKE SURE SEALING GASKET IS IN PLACE ON FIREBOX BOTTOM!** Secure with (8) screws previously removed.
2. Reinstall light bar onto control board, secure with (2) nuts previously removed.
3. Reinstall burner, positioning burner venturi over burner orifice, aligning burner tube with mounting cradles on control board. Re-install burner venturi housing.
4. Reinstall burner cover, aligning holes in cover to corresponding holes in burner tube mounting cradles. Secure with screws (10).
5. Reinstall glass media, being careful not to block pilot.
6. Reconnect gas line to manual shut-off on the valve.
7. Reconnect all wiring harnesses to gas valve, Plug all components into electrical outlet.
8. Reinstall glass frame assembly.
9. Turn on main gas line feeding appliance.
10. Verify proper glass media placement, operation of fireplace, and any electrical components.

Figure 13.6, Control Board Removal and Assembly

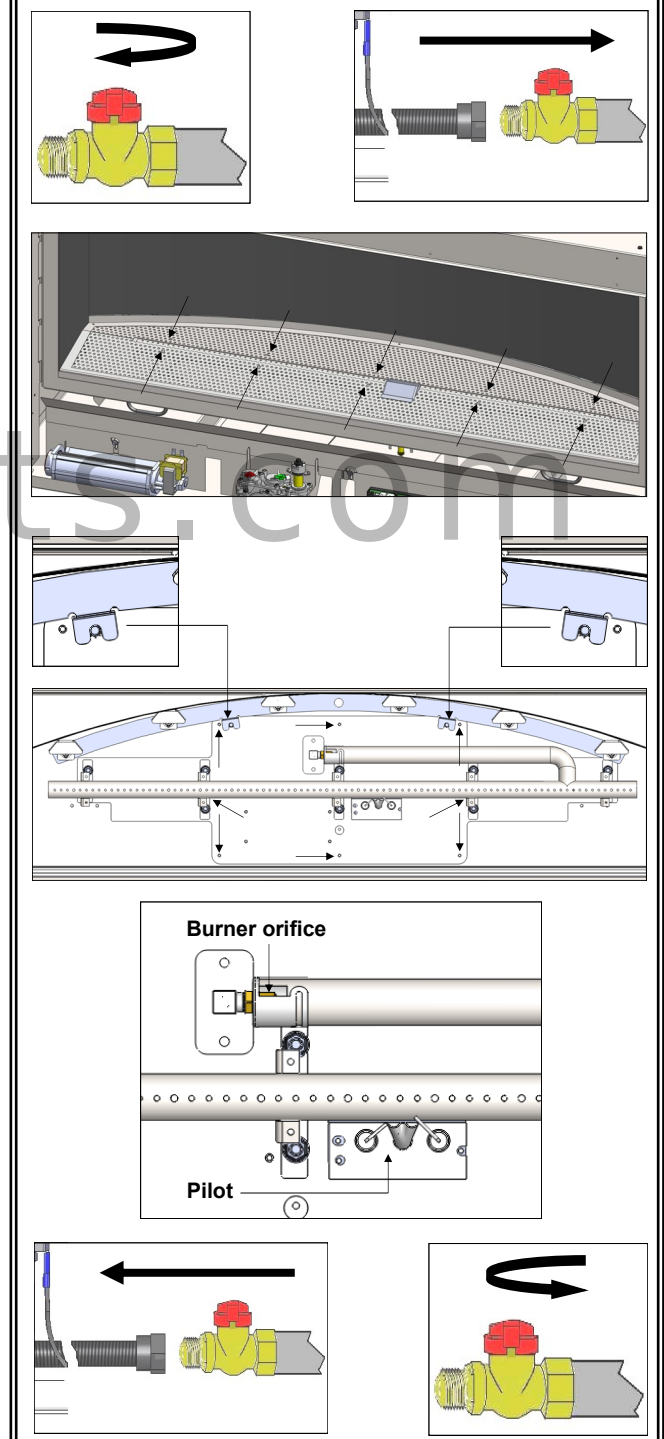

CAUTION

CHECK ALL CONNECTIONS FOR LEAKS WITH SOAPY WATER, WHETHER FIELD OR FACTORY MADE.

14.0 CONTROL SYSTEM COMPONENTS

14.1 Remote Control

Figure 14.1, Remote Control Diagram

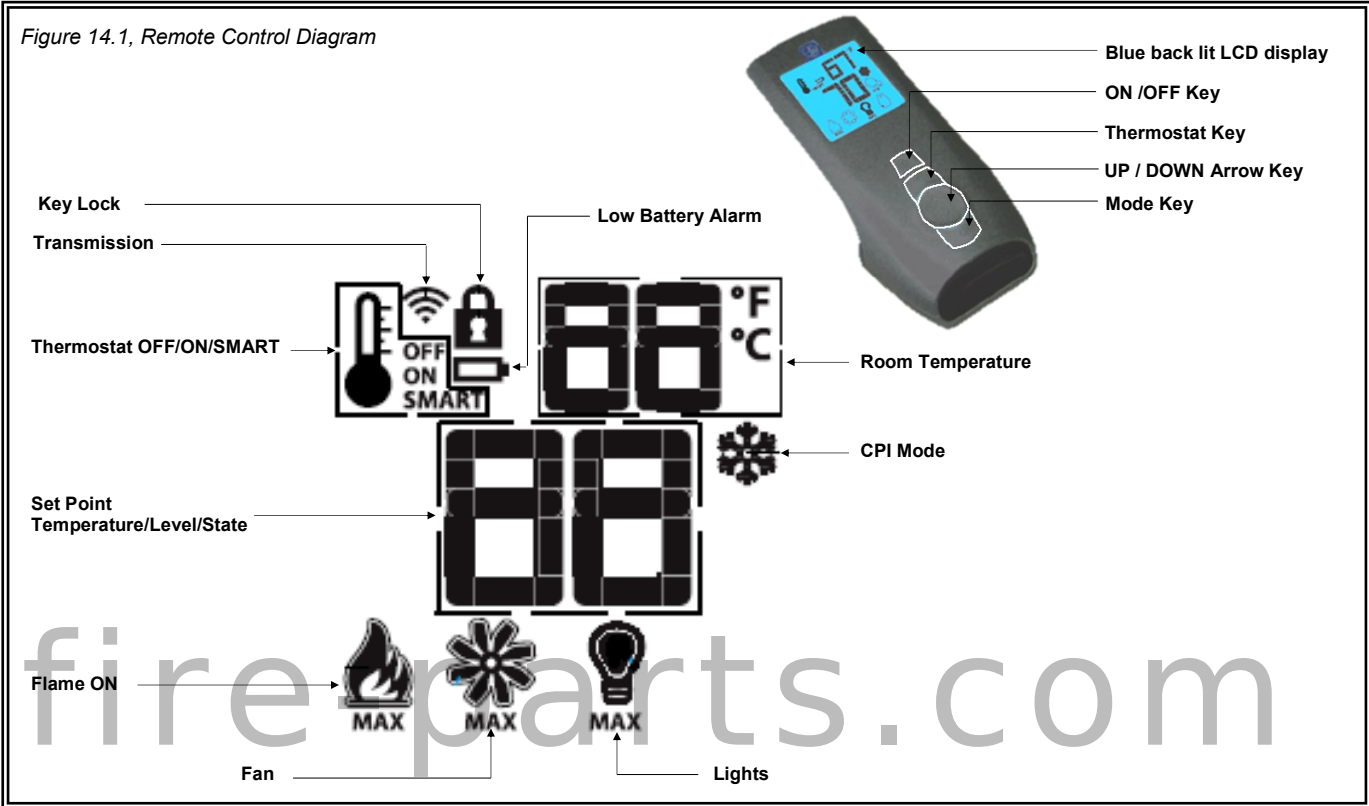

14.2 Gas Valve

Figure 14.2, Gas Valve Diagram

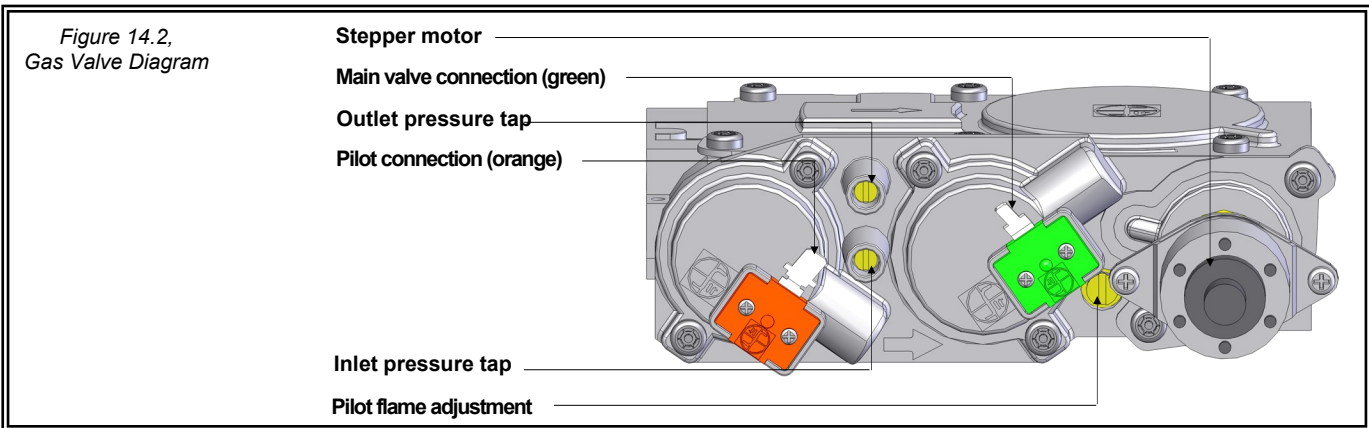

14.3 Pilot Assembly

Figure 14.3, Pilot Assembly Diagram

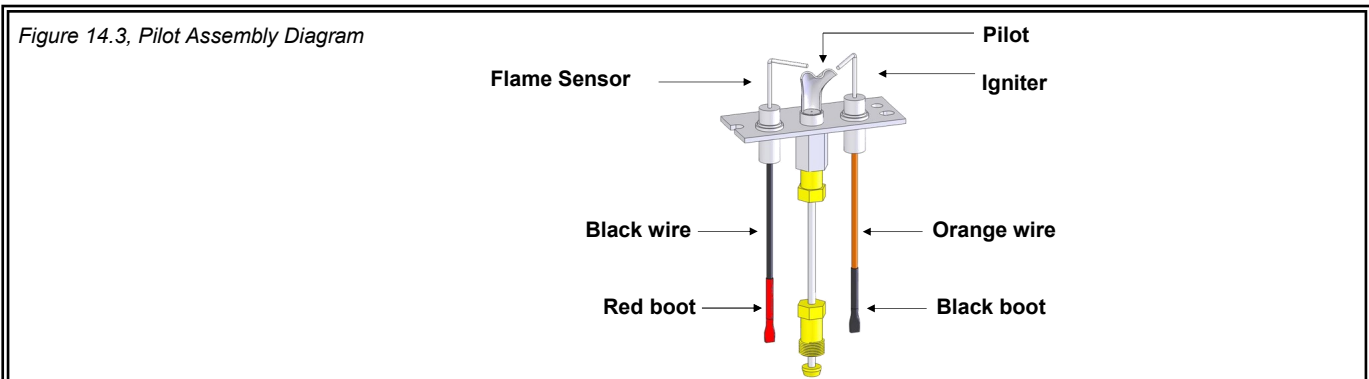

15.0 SYSTEM OPERATION

15.1 Initializing the System for the First Time

1. Set ON/OFF rocker switch to OFF position.
2. Install 4 AA batteries (included in components packet) into battery backup holder.
3. Connect IFC Control Module to AC power supply.
4. Install 3 AAA batteries (included in components packet) into remote control battery bay (located on base of remote control).

NOTE: Performing the next step will initiate Pilot Start-up in Manual Mode:
Pilot igniter will spark repeatedly.
Pilot will ignite if gas is supplied to the fireplace.

Remove all packaging / combustable material from fireplace before proceeding.

5. Press red SW1 button on IFC control module until module beeps three (3) times and/or an amber LED is illuminated indicating the IFC control module is ready to synchronize with the remote control.
6. Within five (5) seconds push remote control **ON/OFF** button. The IFC control module will beep (4) times to indicate the remote control's command is accepted and set to the particular code of that remote control. Press remote control **ON/OFF** button again. The pilot will shut down indicating the remote has taken over. The system is now initialized.
7. Setting ON/OFF rocker switch to ON position will allow you to operate fireplace with remote control.

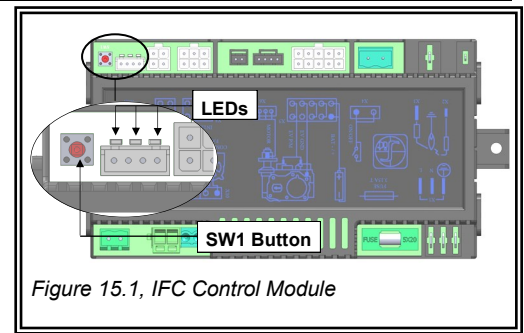

15.2 Temperature Display

With the system in **OFF** position, press Thermostat Key and Mode Key at the same time to change from degrees F to degrees C. Look at the remote control LCD screen to verify that C or F is visible on right side of Room Temperature display.

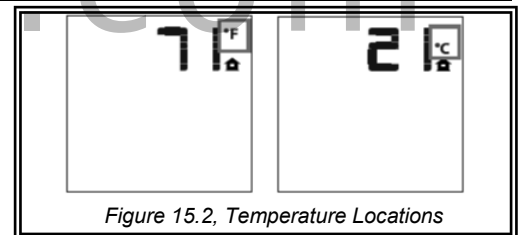

15.3 Turn ON the Appliance

Press **ON/OFF** key on remote control. The display will show all active icons on the screen. A single 'beep' from IFC Control Module will confirm reception of the command.

15.4 Turn OFF the Appliance

Press **ON/OFF** key on remote control. The display will show only room temperature and icon on the screen. A single 'beep' from IFC control module will confirm reception of the command.

15.5 Manually Control Flame with Remote Control

The remote control has six (6) flame levels. With system ON and flame level at maximum, press Down Arrow Key once to reduce flame height by one step until flame is turned off. The Up Arrow Key will increase flame height on step each time it is pressed. If Up Arrow Key is pressed while system is on but flame is off, the flame will come on in High position. A single 'beep' will confirm reception of the command. When SMART Thermostat is activated, manual flame height adjustment is disabled.

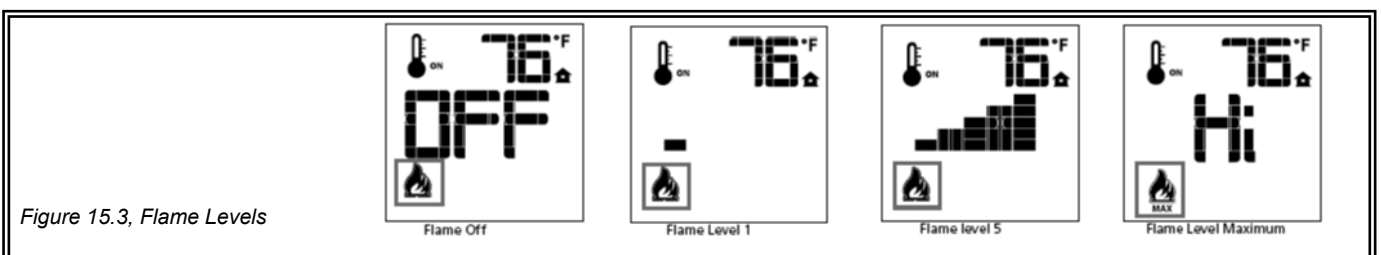

15.6 Remote Control Thermostat Operation

15.6.1 Room Thermostat

The remote control can operate as a room thermostat. The thermostat can be set to desired temperature to control a rooms comfort level.

To activate this function, press the Thermostat Key. The LCD display will change to show the room thermostat is ON and set temperature is now displayed. To adjust set temperature, press Up or Down arrow keys until desired set temperature is display on LCD screen.

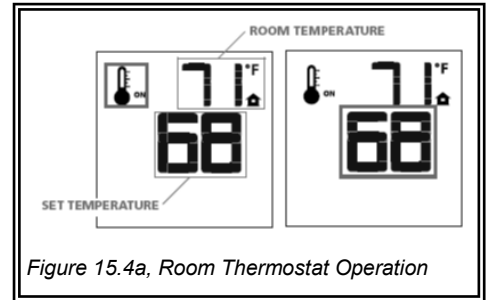

Figure 15.4a, Room Thermostat Operation

15.6.2 Smart Thermostat

The Smart Thermostat function adjusts flame height based on set temperature and actual room temperature. As room temperature gets closer to set point the Smart Function will automatically adjust flame down.

1. Press Thermostat key until word SMART appears on right side of temperature bulb graphic.
2. To adjust set temperature, press Up/Down arrow keys until desired set temperature is displayed on LCD screen.

When SMART Thermostat is activated, manual flame height adjustment is disabled.

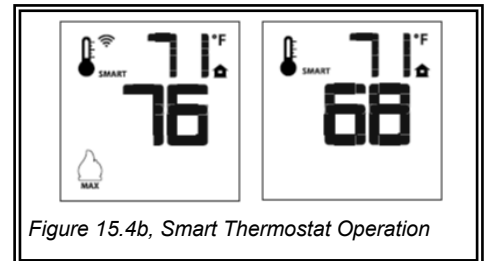

Figure 15.4b, Smart Thermostat Operation

15.7 Fan Speed Control

Fan speed can be adjusted through six (6) speeds. To activate this function use Mode Key to index to fan control icon. Use Up/Down Arrow Keys to turn on, off or adjust fan speed. A single 'beep' will confirm reception of the command.

In Thermostat Mode: Fan(s) have a five (5) minute delay time when fire-place is lit, allowing time for heat to build in fireplace before operating, and will continue operating for approximately twelve (12) minutes after fireplace has been turned off.

In Manual Mode: Fan (s) will operate at previous setting. There is no delay in start up or stop time.

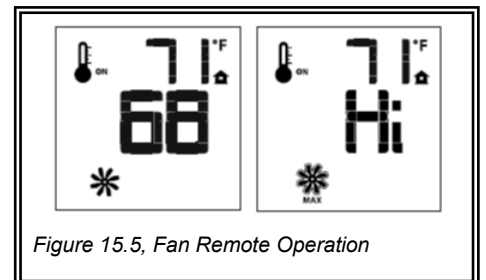

Figure 15.5, Fan Remote Operation

15.8 Accent Light Kit

1. Use MODE key to guide you to LIGHT icon.
2. The light intensity can be adjusted through six (6) levels. Use UP/DOWN Arrow Keys to adjust intensity level. A single beep will confirm reception of the command.

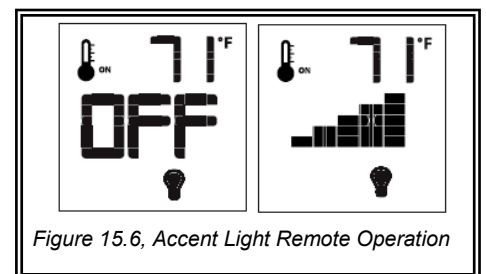

Figure 15.6, Accent Light Remote Operation

15.9 Key Lock

This function locks the keys to avoid unsupervised operation.

To Activate: Press MODE and UP keys at same time.

To De-activate: Press MODE and UP keys at same time.

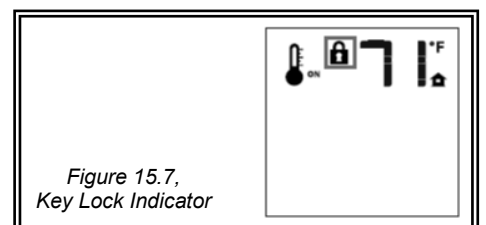

Figure 15.7,
Key Lock Indicator

15.10 Low Battery Detection

REMOTE CONTROL: Remote control battery lifespan depends on various factors

including battery quality, number of ignitions, changes to room thermostat set point, etc. When the remote control batteries are low, a Battery Icon will appear on the LCD display before all battery power is lost. When batteries are replaced this icon will disappear.

BACKUP BATTERY PACK (used when electrical power is interrupted): Backup batteries lifespan depends on various factors including battery quality, number of ignitions, changes to room thermostat set point, etc. When backup batteries are low, a double-beep will be emitted from the IFC control module when it receives an ON/OFF command from the remote control. This is an alert for a low battery condition of the backup batteries and after this double-beep warning, no commands will be accepted until batteries are replaced. When batteries are replaced, a beep will be emitted from IFC control module as soon as powered.

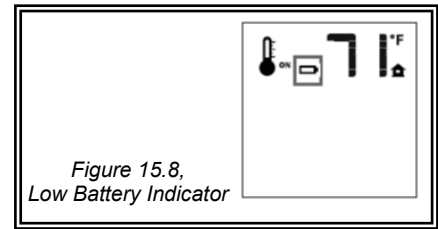

Figure 15.8,
Low Battery Indicator

15.11 Continuous Pilot / Intermittent Pilot (CPI/IPI)

This system has the option of a continuous (standing) pilot feature. This allows you to change from a spark-to-pilot system to a standing pilot system during cold weather conditions. By having the pilot on continuously, the firebox will remain warm and a draft is established in the vent, allowing the main burner to turn on with less air-flow disruption.

With system in OFF position, press Mode Key to index to CPI mode icon. Pressing the UP Arrow Key will activate the Continuous Pilot Ignition Mode (CPI). Pressing the Down Arrow Key will return to IPI. A single beep will confirm the reception of the command.

A snowflake icon will be visible during setup of either IPI or CPI modes.

In IPI mode, the snowflake is not visible on LCD screen.

In CPI mode, the snowflake will remain visible on LCD screen.

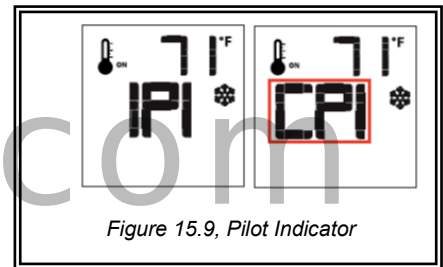

Figure 15.9, Pilot Indicator

15.12 Resetting System for Manual Operation

1. Put ON/OFF switch in OFF position.
2. Press red SW1 button on IFC control module until the IFC control module emits three (3) beeps and an amber LED is illuminated, indicating the IFC control module is ready to synchronize with remote control. Within five (5) seconds press the red SW1 button on IFC control module again. The pilot will automatically light.
3. Turn main burner on by pressing ON/OFF switch to ON position, turn off by pressing ON/OFF switch to OFF position. Pilot will remain lit even if burner is turned off.

When operating fireplace in this capacity, the only function available is burner operation on HI.

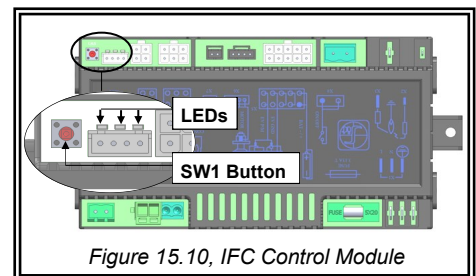

Figure 15.10, IFC Control Module

15.13 Automatic Safety Restart

This system will execute an automatic turn OFF command within (24) hours of a continued pilot flame ignition. This allows the system to verify correct safety functions. After turn OFF sequence is completed, the IFC control module will re-execute the latest command.

15.14 Lock Out Information

15.14.1 Ignition Sequence

Starting from OFF, press remote control ON button. Approximately (4) seconds after ON/OFF button is pushed, the IFC control module will start the spark. First ignition try will last approximately (60) seconds.

If there is no flame ignition (rectification) during the first try for ignition, the IFC control module will stop sparking for approximately (35) seconds. After this wait time, the IFC control module will start the second try for ignition by sparking for approximately (60) seconds. If ignition is successful on third ignition attempt, there will be a (60) second delay before the main burner lights.

If after this third attempt there is still no positive ignition, the IFC control module will go into LOCK OUT and the red LED will blink (3) times in intervals until the system is reset.

LED Indicator Location: Corner of IFC control module. (IFC control module location determined by fireplace model and design. It also may be located in component housing behind lower grill, or behind left side access panel).

LOCK OUT = LED blinks (3) times in intervals until the system is reset.

In Summary:

1. The IFC control module will try (2) times for ignition.
2. Each try for ignition will last approximately (60) seconds.
3. The wait time between the two tries is approximately (35) seconds.

15.14.2 Reset IFC Control Module—Lock Out

Reset Using ON/OFF Switch:

Set ON/OFF switch to OFF position. Wait approximately (2) seconds and move switch to the ON position. The ignition sequence will start again.

Reset Using Remote Control ON/OFF Button:

Turn the system off by pressing the remote control ON/OFF button. After approximately (2) seconds press the remote control ON/OFF button again. The IFC control module will reset and the ignition sequence will start again.

Reset By Cycling Flame:

In the Manual Flame Control Mode, use the Down Arrow Button to reduce flame to off (indicated by OFF displayed on Remote Control Display Screen). Wait approximately (2) seconds and press the Up Arrow Button, the ignition sequence will start.

15.15 Additional Diagnostic Indications Information

Low Battery Condition (<4V) Remote Control: Battery Icon will appear on LCD remote control display. Replace batteries.

Low Battery Condition (<4V) Battery Backup: Red LED Indicator will blink (1) time in intervals. Low double-beep emitted from IFC control module when it receives an ON/OFF command from the remote control. Replace Batteries.

Pilot Flame Error Condition: Red LED Indicator will blink (2) times in intervals. Contact your dealer if this occurs.

System Lock Out Condition: Red LED Indicator will blink (3) times in intervals. Make sure gas is turned on. Make sure sensor is not shorted. Follow 15.14.2, **Reset IFC Control Module—Lock Out** instructions.

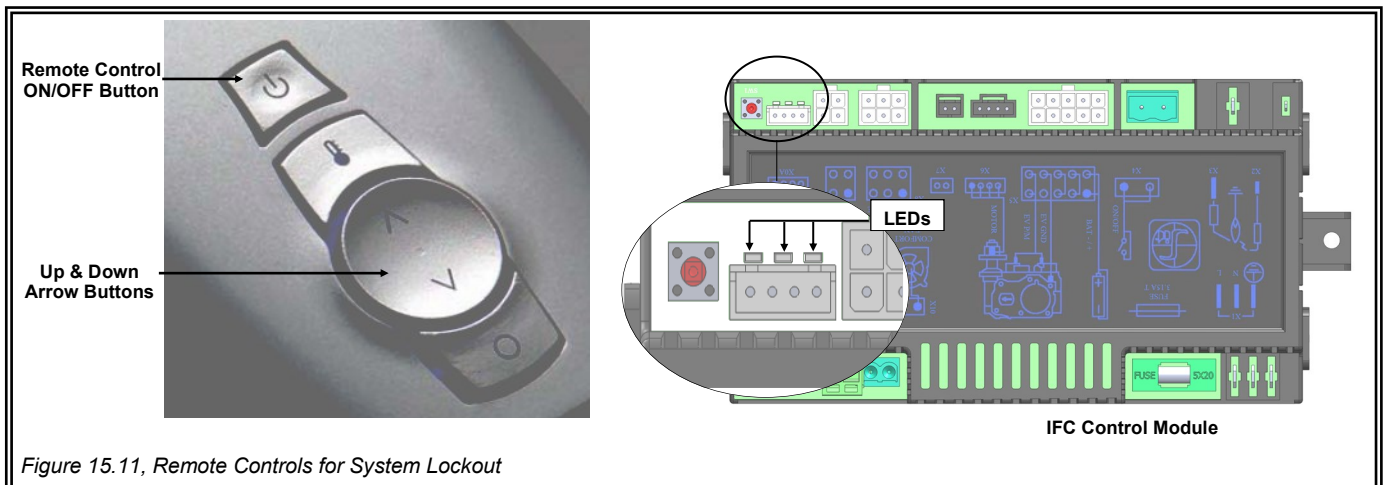

16.0 LIGHTING AND SHUTDOWN

FOR YOUR SAFETY—READ BEFORE OPERATING

WARNING

IF YOU DO **NOT** FOLLOW THESE INSTRUCTIONS EXACTLY, A FIRE OR EXPLOSION MAY RESULT, CAUSING PROPERTY DAMAGE, PERSONAL INJURY, OR LOSS OF LIFE.

This appliance is equipped with an ignition device which automatically lights the pilot. **DO NOT** try to light the pilot by hand.

BEFORE OPERATING, smell all around the appliance area for gas. Be sure to smell next to the floor because some gas is heavier than air and will settle on the floor.

WHAT TO DO IF YOU SMELL GAS:

- * Do not try to light any appliance.
- * Do not touch any electrical switch; do not use any phone in your building.
- * Immediately call your gas supplier from a neighbor's phone. Follow the gas supplier's instructions.
- * If you cannot reach your gas supplier, call the fire department.

Do not use this appliance if any part has been under water. Immediately call a qualified service technician to inspect the appliance, and to replace any part of the control system / any gas control which has been under water.

WARNING

CHILDREN AND ADULTS SHOULD BE ALERTED TO THE HAZARDS OF HIGH SURFACE TEMPERATURES AND SHOULD STAY AWAY TO AVOID BURNS OR CLOTHING IGNITION. YOUNG CHILDREN SHOULD BE CAREFULLY SUPERVISED WHEN THEY ARE IN THE SAME ROOM AS THE APPLIANCE.

CLOTHING OR OTHER FLAMMABLE MATERIAL MUST NOT BE PLACED ON OR NEAR THE APPLIANCE.

DO NOT STORE OR USE GASOLINE OR OTHER FLAMMABLE VAPORS AND LIQUIDS IN THE VICINITY OF THIS OR ANY OTHER APPLIANCE.

NOTE

A PAINT SMELL WILL OCCUR DURING THE FIRST FEW HOURS OF BURNING. IT IS RECOMMENDED TO LEAVE THE FAN OFF DURING THIS PERIOD TO HELP SPEED THE PAINT CURING PROCESS.

THIS FIREPLACE MAY PRODUCE NOISES OF VARYING DEGREE AS IT HEATS AND COOLS DUE TO METAL EXPANSION AND CONTRACTION. THIS IS NORMAL AND DOES NOT AFFECT THE PERFORMANCE OR LONGEVITY OF THE FIREPLACE.

DUE TO HIGH SURFACE TEMPERATURES, KEEP CHILDREN, CLOTHING, AND FURNITURE AWAY.

This appliance needs fresh air for safe operation, and must be installed so there are provisions for adequate combustion and ventilation air.

STOP!

Read safety information on previous page and front cover of this manual before continuing.

16.1 Operating Instructions

1. Turn off all electric power to the appliance.

ATTENTION

This appliance is equipped with an ignition device which automatically lights the pilot. **DO NOT** try to light the pilot by hand.

2. Press hand held remote **OFF** button.
3. Wait five (5) minutes to clear out any gas. After 5 minutes, smell for gas, including near the floor. If you smell gas, **STOP!** Follow 'WHAT TO DO IF YOU SMELL GAS' on the previous page. If you do not smell gas, proceed to next step.
4. Turn ON all electric power to the appliance.
5. Press hand held remote **ON** button.

Figure 16.1, Steps for Operating Appliance

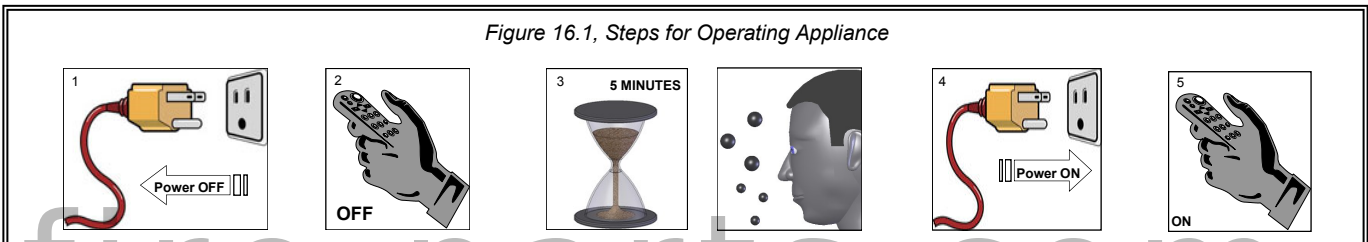

CAUTION

If the fireplace will not operate, follow instructions 16.2, To Turn Gas Off to Appliance, and call your service technician or the gas supplier.

NOTE

When the fireplace is initially lit, condensation will appear on the glass. This is normal in all gas fireplaces and will disappear after several minutes.

16.2 To Turn Gas Off to Appliance

1. Press the hand held remote **OFF** button.
2. Turn OFF all electric power to appliance if service is to be performed.
3. Turn manual shut-off valve to **OFF**. The manual shut-off valve is located underneath the lower louver, on the left side of the gas valve.

Figure 16.2, Steps for Manual Gas Valve Shut-Off

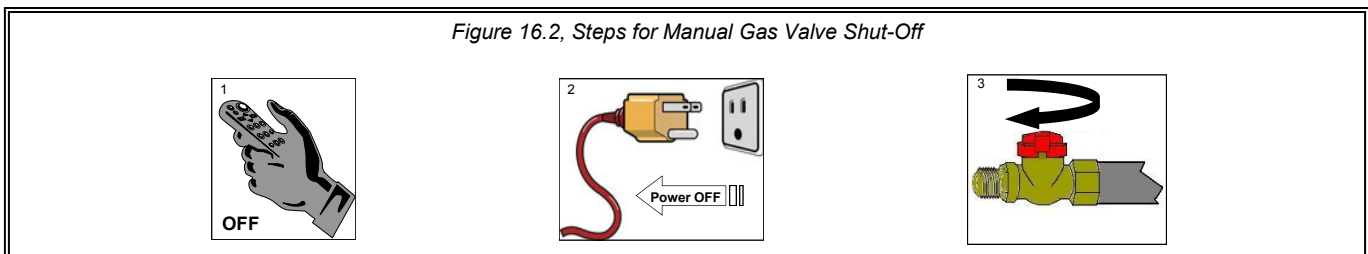

17.0 PRESSURE TESTING

IMPORTANT

Pressure check taps for manifold (outgoing) and inlet (incoming) pressure have been incorporated into the valve. The pressure tap marked OUT measures outgoing pressure and the pressure tap marked IN measures incoming pressure. Follow instructions 17.1 and 17.2 for proper testing procedures. For manifold pressures, refer to 2.3, Gas Information, on page 5.

NOTE

The appliance and its appliance main gas valve must be disconnected from the gas supply piping system during any pressure testing of the system at test pressures in excess of 1/2 psi (3.5 kPa). The appliance must be isolated from the gas supply piping system by closing its equipment shutoff valve during any pressure testing of the gas supply piping system at test pressures equal to or less than 1/2 psi (3.5 kPa).

17.1 Inlet Pressure Test

NOTE: Make sure to apply the incoming pressure test with all other gas appliances on, or at full capacity in the house for proper pressure reading.

1. Loosen inlet (IN) pressure tap screw (counter-clockwise).
2. Attach manometer using a 1/4 in. (6 mm) I.D. hose.
3. Light pilot and burner. Check pressure to ensure it is between the minimum and maximum recommended pressure settings.
4. Turn off burner and pilot.
5. Disconnect hose and tighten inlet (IN) pressure tap screw (clockwise). Screw should be snug. Do not over tighten.
6. Relight pilot and burner. Then reattach manometer to the inlet pressure tap to verify the tap is completely sealed. Manometer should read no pressure.

NOTE

If the inlet pressure reading is too high or too low, contact the gas company. Only a qualified gas service technician should adjust incoming gas pressure.

CAUTION

A LOW PRESSURE READING CAN CAUSE DELAYED IGNITION.

17.2 Manifold Pressure Test

1. Light pilot.
2. Loosen manifold (OUT) pressure tap screw (counter-clockwise).
3. Attach manometer to pressure tap using a 1/4-in I.D. hose.
4. Light burner. Check manometer reading.
5. Turn burner and pilot off.
6. Disconnect manometer hose and tighten manifold (OUT) pressure tap screw (clockwise). Screw should be snug. Do not over tighten.
7. Attach the manometer to the manifold pressure tap to verify it is completely sealed. The manometer should read no pressure when pilot and burner are on.

Figure 17.1, Test Pressure Locations

Outlet (Manifold) Pressure Screw

Inlet Pressure Screw

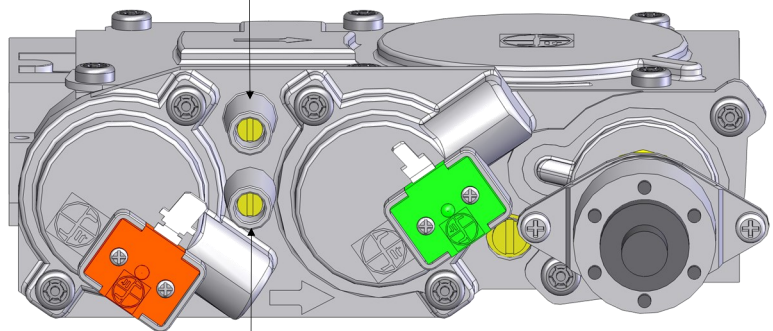

18.0 FINALIZING THE INSTALLATION

18.1 Flame Appearance

Flame appearance is affected by several factors; including altitude, venting configuration, and fuel quality. Although the venturi setting has been factory set, adjustments may be necessary for optimal performance and visual aesthetics.

When the fireplace is first lit, the flames will be blue. Flames will gradually turn yellowish-orange during the first 15 minutes of operation. If flames remain blue, or become dark orange with evidence of sooting (black tips), the burner tube venturi may need adjustment.

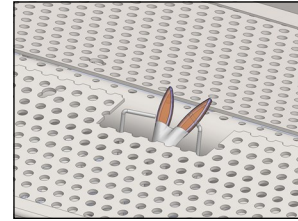
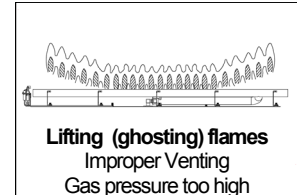
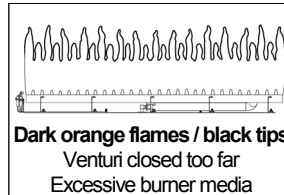
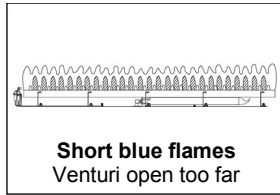
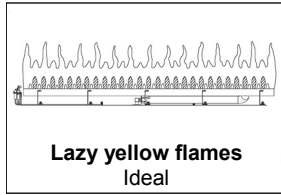

Figure 18.1, Correct pilot flame

Figure 18.2, Flame Appearance Troubleshooting



18.2 Burner Tube Venturi

WARNING

Burner tube adjustable venturi positioning should only be performed by a qualified personal service technician.

IMPORTANT

Slight adjustments to venturi opening will create dramatic results. Adjust at slight increments until desired look is achieved. Always burn the fireplace for at least 15 minutes, and allow the appliance time to cool before making any further adjustments.

18.2.1 Venturi Adjustment

WARNING

To avoid property damage or personal injury, allow the fireplace ample time to cool before making any adjustments.

Table 18.1, Factory Set Burner Tube Venturi Settings (adjust as necessary for your installation)

Natural Gas	LP (Propane) Gas
1/8 in. (3 mm) OPEN	5/8 in. (16 mm) OPEN

1. Remove glass frame assembly, glass media, burner venturi housing, burner cover and burner from the fireplace.
2. Loosen burner venturi screw and make the adjustment, then retighten screw.
3. Re-install burner, making sure venturi is positioned over burner orifice. Re-install burner venturi housing.
4. Reinstall burner cover, glass media, and glass frame assembly.
5. Light fireplace. Wait at least 15 minutes before determining if any further adjustments are necessary.

Figure 18.3, Burner Venturi

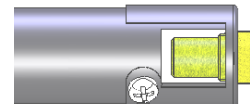

Table 18.2, Burner Tube Venturi Adjustment and Flame Appearance

Venturi Position	Flame Color	Venturi Adjustment
Closed too far	Dark orange flame with black tips	Open venturi setting slightly
Open too far	Blue flames	Close venturi setting slightly

18.3 Restrictors

WARNING

To avoid property damage or personal injury, allow the fireplace ample time to cool before making any adjustments/installations.

18.3.1 Restrictor Usage

- Turn fireplace on and allow to burn for 15 minutes.
- If flames indicate there is excessive draft (flickering, short flames), a restrictor may be necessary.
- If flames indicate insufficient draft (lifting or ghosting flames), a previously installed restrictor may need to be modified or removed.

Table 18.3, Restrictor Troubleshooting

Flame Appearance	Draft Problem	Restrictor Solution
Short, flickering	Excessive draft - not enough restriction	Add restrictor
Lifting or ghosting*	Insufficient draft - too much restriction	Remove inner ring(s) on restrictor or remove restrictor

*Improper venting installation may cause flames to lift or "ghost" - a dangerous situation. Inspect flames after installation to ensure proper performance. If determined that venting is correct, and the restrictor has been removed, yet flames are still lifting or ghosting, shut off gas supply to fireplace and call a qualified service technician.

18.3.2 Restrictor Installation and Modification

If it is determined that a restrictor is needed or restrictor modification is required after termination is installed, access can be reached through the fireplace baffle.

1. Remove glass frame assembly. Refer to 13.1.1, Remove Glass Frame Assembly, on page 29.
2. Remove (2) screws securing termination access panel. Release panel tabs from slots in baffle.
3. Depending on your specific needs, determined by Table 18.3, along with other factors, to make necessary modifications.
4. If installation of a restrictor (included in fireplace components packet) is necessary, bend tabs on restrictor to approximately 80° angles to create tension when inserted into exhaust pipe on the fireplace. Insert the restrictor into 5 in. exhaust pipe with tabs pointing towards you.
5. If modification is necessary, remove restrictor by pulling it down and out of 5 in. exhaust pipe.
6. Reinstall termination access panel, inserting tabs in panel into slots in baffle. Secure with (2) screws previously removed.
7. Re-install glass frame assembly (refer to 13.1.2, Install Glass Frame Assembly, page 29), and light fireplace. Wait 15 minutes before determining if any further modifications are necessary.

Figure 18.4, Restrictor Installation and Modification

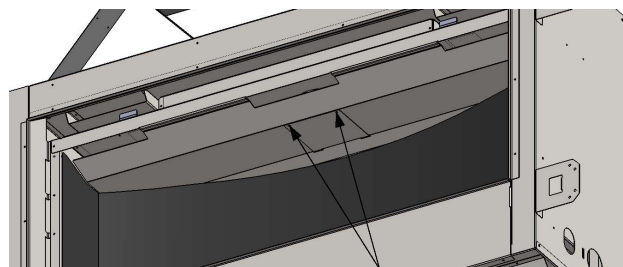

(2) screws securing termination access panel

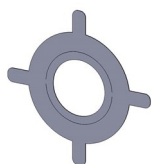

Restrictor

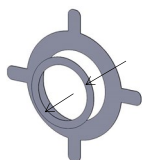

When needed, remove circle to create less restriction

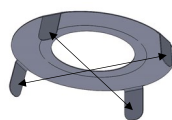

Bend tabs to approx. 80° angles to create tension to hold itself in place when installed.

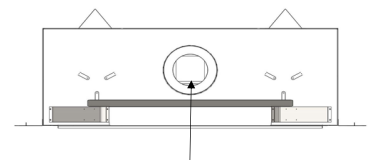

Slide restrictor into exhaust pipe on top of fireplace with tabs pointing towards you prior to attaching venting.

19.0 TROUBLESHOOTING

ATTENTION

TROUBLESHOOTING MUST BE PERFORMED BY A QUALIFIED TECHNICIAN.

Before proceeding with the steps in the following troubleshooting guide, verify the power supply is present, and the receiver batteries / battery pack are fresh and installed with correct polarity.

Make sure all connections between the wire harnesses and the system components are proper and positive.

Make sure the communication link between the remote control and the IFC control module is established.

Verify inlet pressure meets the recommended inlet pressure. If necessary, adjust line pressure regulator.

19.1 Pilot Will Not Light / Stay Lit

- Electrical power interrupted or disconnected. Restore electrical power to fireplace or use battery back-up. Ensure batteries are fully charged if using battery back-up as power source.
- Verify gas supply is turned on. Check the remote shut-off valves from fireplace. Usually there is a valve near the main gas line. There may be more than (1) valve between the fireplace and the main gas line.
- Low gas pressure. Low gas pressure can be caused by several situations such as a bent line, a too narrow diameter pipe, or a low line pressure. Consult a plumber or a gas supplier.
- No LP in tank. Check LP (propane) tank. Refill if necessary.
- Wiring disconnection. Use wiring schematic in this manual to determine that all wiring connections are secure and correct.
- Pilot flame not making contact with the flame rectification sensor on the pilot assembly. This valve is equipped with a pilot flame adjustment screw. Adjust as necessary.
- Pilot adjustment screw not sealed. Seal pilot adjustment screw. Do not over tighten.

19.2 Pilot Flame Always On / Will Not Extinguish

- System set to CPI mode. Set system to IPI mode.

19.3 Main Flame Will Not Light

- ON/OFF rocker switch in OFF position. Switch to ON position.
- Remote not working properly. Replace batteries.
- Remote set to thermostat mode and there is no call for heat. Adjust heat setting.
- Thermostat disconnected or set too high. Set thermostat to lower temperature setting.
- Ensure pilot flame will ignite. If not, see pilot flame troubleshooting above.
- Ensure pilot flame is properly located to ignite main flame.
- Plugged main burner orifice.
- Wiring disconnection / improper wiring. Check for faulty or incorrect wiring.
- Verify gas supply is turned on.
- Low gas pressure. Low gas pressure can be caused by several situations such as a bent line, too narrow diameter pipe, or low line pressure. Consult with plumber or gas supplier.

19.4 Pilot and Burner Extinguish While in Operation

- No LP in tank. Check and refill if necessary.
- Glass frame assembly not installed correctly. Refer to 13.1, Glass Frame Assembly, page 29.
- Improper vent cap installation. Adjust if necessary.
- Vent cap blockage. Remove debris if necessary.
- Improper pitch on horizontal venting. 1/4 in. (6 mm) rise per foot is required on horizontal venting.
- Inner vent pipe leaking exhaust gases back into the firebox. Check for leaks, and repair if necessary.
- Excessive draft.

19.5 Glass Sooting

- Improper glass media placement. Refer to 13.4, Glass Media, on page 31.
- Improper venturi setting. Venturi may need to be opened slightly to allow more air into the gas mix. Refer to 18.2, Burner Tube Venturi, on page 41.
- Improper pitch on horizontal venting. 1/4 in. (6 mm) rise per foot required on horizontal venting.

19.6 Flame Burns Blue and Lifts Off Burner

- Improper venturi setting. Venturi may need to be closed slightly. Refer to 18.2, Burner Tube Venturi, on page 41.
- Improper vent cap installation. Check for proper vent cap installation.
- Blockage or leakage of the vent system.

19.7 No Reaction to Command

- Backup battery pack batteries or remote control batteries low. Replace batteries.
- No communication between remote control and IFC control module. Reprogram remote control to IFC control module. Follow 15.1, Initializing the System for the First Time, on page 34.
- A maximum number of failed ignitions or flame restorations has been reached. Reset IFC control module.

19.7.1 Reset IFC Control Module

Reset Using ON/OFF Switch:

Set ON/OFF switch to OFF position. Wait approximately (2) seconds and move switch to the ON position. The ignition sequence will start again.

Reset Using Remote Control ON/OFF Button:

Turn the system off by pressing the Remote Control ON/OFF button. After approximately (2) seconds press the Remote Control ON/OFF button again. The IFC control module will reset and the ignition sequence will start again.

Reset By Cycling Flame:

In the Manual Flame Control Mode, use the Down Arrow Button to reduce flame to off (indicated by OFF displayed on Remote Control Display Screen). Wait approximately (2) seconds and press the Up Arrow Button, the ignition sequence will start.

20.0 MAINTENANCE

NOTE

Installation and repair shall only be done by a qualified service person. The appliance should be inspected before use by a qualified service person. This appliance is required to be inspected at least once a year by a professional service person.

The compartment below the firebox must be cleaned at least once a year. More frequent cleaning may be required due to excessive lint from carpeting, bedding materials, etc., than outlined in this manual. It is imperative that the control compartments, burners, and circulation air passageways of the appliance be kept clean. Use a vacuum to clean all components.

20.1 Control Board System

- Annual cleaning of the burner system is required. Vacuum all components thoroughly.
- The burner assembly may be removed for easier access. Refer to 13.5.1, Control Board Removal on page 32.
- Visually check for blocked port holes, especially near the pilot. Blocked port holes may cause delayed ignition.
- Reinstall burner assembly. Refer to 13.5.2, Control Board Installation on page 32.
- Visually check pilot light and burner when in operation. The flames should be steady—not lifting or floating.

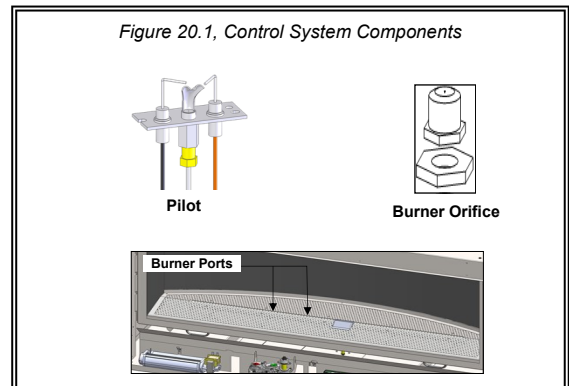

CAUTION

LABEL ALL WIRES PRIOR TO DISCONNECTION WHEN SERVICING CONTROLS. WIRING ERRORS CAN CAUSE IMPROPER AND DANGEROUS OPERATION. VERIFY PROPER OPERATION AFTER SERVICING.

20.2 Fan

- The fan shall be disconnected from electrical current and cleaned (vacuumed) every six months.
- The bearings are sealed and require no oiling.

20.3 Vent System

- Annual examination of venting system by a qualified agency is required.
- The flow of combustion and ventilation air must not be obstructed.
- IF VENT-AIR INTAKE SYSTEM IS DISASSEMBLED FOR ANY REASON, RE-INSTALL PER INSTRUCTIONS PROVIDED WITH INITIAL INSTALLATION. Refer to 11.0 Venting, on page 18.

20.4 Glass Frame Assembly

WARNING

DO NOT OPERATE APPLIANCE WITH THE GLASS FRAME ASSEMBLY REMOVED, CRACKED, OR BROKEN. REPLACEMENT OF THE GLASS SHOULD ONLY BE PERFORMED BY A LICENSED OR QUALIFIED SERVICE PERSON.

IMPORTANT

ANY SAFETY SCREEN OR GUARD REMOVED FOR SERVICING MUST BE REPLACED PRIOR TO OPERATING THE APPLIANCE.

- Clean glass only when cool and only with non-abrasive cleansers.
- Use protective gloves to handle any broken or damaged glass assembly components.
- The glass assembly, part #SL36-057T, shall only be replaced as a complete unit, as supplied by Hussong Mfg. Co., Inc.
- Replacement of the glass and frame assembly, part #SL36-057T, must only be performed by a licensed or qualified service person. DO NOT SUBSTITUTE MATERIALS.
- Do not strike or slam glass frame assembly.

CAUTION

KEEP APPLIANCE AREA CLEAR OF COMBUSTIBLE MATERIALS, SUCH AS GASOLINE, AND OTHER FLAMMABLE VAPORS / LIQUIDS.

21.0 REPLACEMENT PARTS LIST

Replacement parts are available through your local dealer. Contact your dealer for availability and pricing.

CONTROL BOARD AND PARTS

SL36-150	Control Board - Nat Gas	700-504	Valve Step Motor - Natural Gas
SL36-151	Control Board - LP Gas	700-504-1	Valve Step Motor - LP Gas
700-567	SIT IPI Valve - Natural	700-213B	18" Flexible Gas Line-Black
700-567-1	SIT IPI Valve - LP	700-226	Flexible Gas Line-Valve to Burner Connection
700-652	Proflame 2 IFC Control Module	700-237	Natural Gas Orifice #37
700-653	IFC Wire Harness Assembly	700-625	LP Gas Orifice #.0625
700-596	Pilot Assembly - Natural Gas	NCK-SL36-SP	Natural Gas Conversion Kit
700-596-1	Pilot Assembly - LP Gas	LCK-SL36-SP	LP Gas Conversion Kit
700-408	Remote Control	SL36-035	Burner Tube
700-123	.023N Natural Gas Pilot Orifice	SL36-350	Media Tray
700-114	.014LP LP Gas Pilot Orifice		

GLASS & GLASS GASKET

700-185T	Glass with Gasket 16-3/8" (419 mm) x 38-3/8" (975 mm)
SL36-005	Glass Valance (only)
900-006	1-1/8" (29 mm) Glass Gasket with adhesive

LIGHT KIT

SL36-BLK	Light Kit (bottom)
600-676	20W 130V Halogen Bulb

Hussong Manufacturing Co., Inc.
P.O. Box 577
204 Industrial Park Drive
Lakefield, MN 56150-0577
USA

SLA-36

www.kozyheat.com

fire-parts.com

LIMITED WARRANTY

Kozy Heat Limited 10 Year Warranty

This limited 10 Year Warranty will not become effective until the Warranty Registration Form has been completed and mailed to Hussong Manufacturing Co., Inc., P.O. Box 577, Lakefield, MN 56150. This registration form must be received within 30 days of installation. Failure to do so may result in delayed warranty coverage and submission of proof of purchase will be required.

Hussong Manufacturing Co., Inc. warrants to the original purchaser of this Kozy Heat Fireplace, that it is free of defects in materials and workmanship at the time of manufacture.

Subject to the following conditions & requirements, Hussong Manufacturing Co., Inc. extends the following limited warranty under normal use and service, with respect to the Kozy Heat line of gas burning fireplaces.

Year 1

Subject to the conditions & requirements listed below, within the first year from date of purchase, Hussong Manufacturing Co., Inc. shall, at its discretion, replace or repair any such defect in material or workmanship, at Hussong Manufacturing Co., Inc.'s expense, including reasonable labor costs to repair or replace the defective component, if a factory pre-authorization is given for the repair.

Years 2 through 10

Subject to the conditions & requirements listed below, beginning with the first day of the second year and continuing through the tenth year, Hussong Manufacturing Co., Inc., will at its discretion, provide repair or replacement parts at current list prices for any defect in material or workmanship of components, including optional components and accessories (if available). Hussong Manufacturing Co., Inc. shall not be responsible for any installation, labor, transportation of other indirect costs.

Limitation of Liability

To make a claim under this warranty, the purchaser must first contact the dealer/installer from whom the fireplace was purchased.

This limited warranty will be void if the fireplace is not installed by a qualified installer and according to the installation instructions. Use of unauthorized components will make this warranty null and void.

This limited warranty also is void if the fireplace is not operated, at all times, according to the operating instructions furnished.

This warranty is limited to defects in material and workmanship. It does not apply to any product that has been subject to negligence, misapplication, improper installation.

No person is authorized to extend the time of this warranty or to accept on Hussong Manufacturing Co., Inc.'s behalf any additional obligation of liability connected with the unit.

It is expressly agreed and understood that this warranty is Hussong Manufacturing Co., Inc.'s sole obligation and purchaser's exclusive remedy for defective fireplace equipment. Hussong Manufacturing Co., Inc. shall not be liable for any consequential, incidental or contingent damages whatsoever. The foregoing warranty is exclusive and in lieu of all other expressed warranties. Hussong Manufacturing Co., Inc. shall not be held to implied warranties or merchantability and fitness for a particular purpose. This warranty replaces all previous warranty policies.

Some states do not allow the exclusion or limitation of incidental or consequential damages or limitations on how long an implied warranty lasts, so the above limitations or exclusions may not apply to you. This warranty gives you specific legal rights and you may also have other rights which vary from state to state.

Hussong Manufacturing Co., Inc. reserves the right to make changes at any time, without notice, in design, material, specifications and prices. Hussong Manufacturing Co., Inc. reserves the right to discontinue models and products.

Warranty Conditions and Requirements

1. You are the original purchaser. This warranty is not transferable.
2. Installation of the fireplace is performed by a qualified installer.
3. Installation and operation must comply with installation and operation instructions.
4. Paint and glass gaskets are covered for 30 days from date of purchase.
5. Remote controls and all optional accessories are covered for 1 year from date of purchase.
6. This warranty does not offer coverage for Light Bulbs or Batteries (whether factory, dealer or installer supplied). This includes any damage stemming from either component's nonuse.
7. Components broken, (including glass panels), during shipping, careless handling of components, or defects resulting from improper installation, misuse of the fireplace and components are not covered under this warranty.
8. This warranty does not cover any part of the fireplace or any components which have been exposed to or submerged underwater.
9. Hussong Manufacturing Co., Inc. must be notified by the dealer the fireplace was purchased from or a qualified installer/service technician of the defect.
10. Annual service of the fireplace as required in the installation manual, is performed by a qualified installer/service technician. (Copies of such service records may be required to claim a warranty).
11. All previous warranty/service has been performed by a qualified installer or service technician. (Copies of such service records may be required to claim a warranty).

fire-parts.com

LIFETIME WARRANTY

THIS LIFETIME WARRANTY COVERAGE WILL BE EXTENDED AS DESCRIBED BELOW PROVIDED ALL WARRANTY CONDITIONS AND REQUIREMENTS ARE MET AS OUTLINED IN THE 10 YEAR LIMITED WARRANTY POLICY.

Lifetime Warranty Coverage

LIFETIME WARRANTY IS EXTENDED AS FOLLOWS: Hussong Manufacturing Co., Inc. warranties to the original purchaser that the firebox, heat exchanger, fiber logs, burner tube and glass panel of this Kozy Heat Fireplace will not be defective in material or workmanship under normal use and service for as long as you own this product. If any of these components fail due to defects in material and workmanship under normal use and service, Hussong Manufacturing, Co., Inc. will, at its sole discretion, repair or replace the defective component. This LIFETIME WARRANTY does not cover any installation, labor, transportation or other indirect cost arising from defective components.

Limitation of Liability

This Lifetime Warranty will be void if the fireplace is not installed by a qualified installer and according to the installation instructions. Use of unauthorized components will make this warranty null and void. This Lifetime Warranty also is void if the fireplace is not operated, at all times, according to the operating instructions furnished. This warranty is limited to defects in material and workmanship of components specified. It does not apply to any product that has been subject to negligence, misapplication, improper installation.

No person is authorized to extend the time of this Lifetime Warranty or to accept on Hussong Manufacturing Co., Inc.'s behalf any additional obligation of liability connected with the unit.

Hussong Manufacturing Co., Inc. may fully discharge all obligations with respect to this Lifetime Warranty by refunding the wholesale price of the defective component(s).

It is expressly agreed and understood that this Lifetime Warranty is Hussong Manufacturing Co., Inc.'s sole obligation and original purchaser's exclusive remedy for defective fireplace equipment. Hussong Manufacturing Co., Inc. shall not be liable for any consequential, incidental or contingent damages whatsoever other than those incurred by Hussong Manufacturing Co., Inc. to repair or replace the defective component. The foregoing warranty is exclusive and in lieu of all other expressed warranties. Hussong Manufacturing Co., Inc. shall not be held to implied warranties, including but not limited to the implied warranties or merchantability and fitness for a particular purpose. This lifetime warranty replace all previous lifetime warranty policies.

Hussong Manufacturing Co., Inc. reserves the right to make changes at any time, without notice, in design, material, specifications and prices. Hussong Manufacturing Co., Inc. reserves the right to discontinue models and products.

To activate this Lifetime Warranty coverage, this registration card must be completed and mailed with your completed 10 Year Limited Warranty form within 30 days of installation to the following address:

Hussong Manufacturing Co., Inc.
P.O. Box 577
204 Industrial Park Drive
Lakefield, MN 56150-0577

September 2011

CUT ALONG DOTTED LINE

PURCHASER NAME: _____
ADDRESS: _____

TELEPHONE: _____

INSTALLATION DATE: _____
MODEL #: _____
SERIAL #: _____

INSTALLER NAME: _____
ADDRESS: _____

TELEPHONE: _____

