



Liberty® L234 Gas Insert

MODELS: L234-NG11 Natural Gas L234-LP11 Propane

Owners & Installation Manual



Liberty L234 Product Video

⚠ Warning
Fire or Explosion Hazard
Failure to follow safety warnings exactly could result in serious injury, death, or property damage.

- Do not store or use gasoline or other flammable vapors and liquids in the vicinity of this or any other appliance.
- **WHAT TO DO IF YOU SMELL GAS**
 - Do not try to light any appliance.
 - Do not touch any electrical switch: do not use any phone in your building. Leave the building immediately.
 - Immediately call your gas supplier from a neighbour's phone. Follow the gas supplier's instructions.
 - If you cannot reach your gas supplier, call the fire department.

Installation and service must be performed by a qualified installer, service agency or the gas supplier.

Tested by:



Certified to/Certifié pour: CSA 2.17-2017
ANSI Z21.88-2019
CSA 2.33-2019

Installer: Please complete the details on the back cover and leave this manual with the homeowner.

Homeowner: Please keep these instructions for future reference.

REGENCY GAS FIREPLACE INSERT

TO THE NEW OWNER

Congratulations! You are the owner of a state-of-the-art Gas Insert by Regency.

The L234 Direct Vent Gas Insert has been designed to provide you with all the warmth and charm of a fireplace, at the flick of a switch. The L234-NG11 and L234-LP11 have been approved by Warnock Hersey /Intertek for both safety and efficiency.

As it also bears our own mark, it promises to provide you with economy, comfort and security for many trouble free years to follow. Please take a moment now to acquaint yourself with these instructions and the many features of your Regency Fireplace.



DANGER

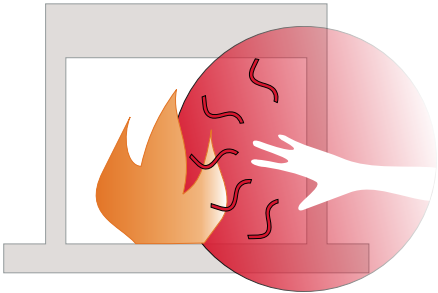

**HOT GLASS WILL
CAUSE BURNS**

**DO NOT TOUCH GLASS
UNTIL COOLED**

**NEVER ALLOW CHILDREN
TO TOUCH GLASS**

A barrier designed to reduce the risk of burns from the hot viewing glass is provided with this appliance and must be installed for the protection of children and other at risk individuals.

CAUTION:

**HOT WHILE IN OPERATION. DO NOT TOUCH.
SEVERE BURNS MAY RESULT. KEEP CHILDREN, CLOTHING, FURNITURE,
GASOLINE, AND ANY OTHER LIQUIDS WITH FLAMMABLE VAPOURS AWAY.**

**KEEP BURNER AND CONTROL COMPARTMENT CLEAN.
SEE INSTALLATION AND OPERATING INSTRUCTIONS ACCOMPANYING
APPLIANCE.**

920-408



**NATIONAL
FIREPLACE
INSTITUTE**

**NFI
CERTIFIED**
www.nficertified.org

We recommend that our products be installed and serviced by professionals who are certified in the U.S. by the National Fireplace Institute® (NFI) or in Canada by Wood Energy Technical Training (WETT).



**Wood Energy
Technical Training**
www.wettinc.ca



Liberty L234 Product Video



Regency Liberty
Gas Inserts Benefits Video

Owner's information

Copy of Safety Decal	4
Unit Dimensions	6
For Your Safety	9
Lighting / Shutdown Procedure	10
Copy of Lighting Plate Instructions	11
Proflame I Remote Control Operating Instructions	12
Proflame I Receiver Battery Replacement	16

Warranty	48
-----------------------	-----------

Installer's information

MA Code - CO Detector	5
-----------------------------	---

Installation

Gas Installation Checklist	7
Important Message	17
Gas Pressure Testing	17
Specifications	17
General Safety Information	17
Gas Pressure Testing	18
Installation into a Solid Fuel Burning Fireplace or Factory Built Fireplace	18
Before You Start	18
Factory-Built (Metal) Wood-Burning Fireplace Requirements	18
Installation Checklist	19
Materials Required	19
Minimum Fireplace Opening	19
Minimum Clearances to Combustibles	20
Combustible Mantel Clearances	20
Venting	21
Converting from 3" & 3" Venting to 3" & 2"	22
Venting Restrictor Position	22
Flue Liner Installation	23
Gas Connection	23
Gas Insert Aeration Adjustment	24
Gas Pipe Pressure Testing	25

On Demand Pilot (seven day safety timer) Important information

This appliance is a Millivolt Standing Pilot system fitted with the "On Demand" Pilot, a safety feature which will shut down the gas valve completely by extinguishing the pilot light in the event of a continuous full seven days of inactivity.

Each time the main burner shuts down, manually or through the call from the thermostat, the seven day timer starts again.

While on these Standing Pilot Systems the control valve is controlled manually, the seven day inactivity timer is controlled by a circuit board. Therefore, if and when the pilot light is extinguished after seven straight days of inactivity, the control knob will remain in the "ON" position and the pilot will be unable to be re lit until the pilot control knob is manually returned to the "OFF" position in order to facilitate and to restart the ignition and relighting process.

If the unit never goes as long as seven full days without a call for heat, the pilot will remain lit until it is manually shut-off.

See the instructions in this manual and on the Lighting Instructions plate on the appliance to light or relight the pilot.

SIT 829 Valve Description	25
Conversion Kit from NG to LP	26
Optional Brick Panel Installation	27
Safety Screen Install	28
Glass Door Removal / Install	28
Log Set Installation	29
Low Profile Faceplate Installation	33
Hearth Trim Installation	34
Wiring Diagrams	35
Optional Wall Thermostat	36
Final Check	36
DC Spark Igniter Battery Installation	36

Operation

First Fire	37
Operating Instructions	37
Lighting Procedure	37
Shutdown Procedure	37
Normal Operating Sounds of Gas Appliances	38

Maintenance

Maintenance Instructions	39
General Vent Maintenance	39
Log Replacement	39
Glass Gasket	39
Door Glass	39
Fan Replacement	40
Valve Replacement	42
Gas Maintenance	44

Parts List

Main Assembly	45
Low Profile Faceplate	47

Warranty

Warranty	48
Recycling	54

This appliance does not have the capability to adjust the fan speed using the supplied remote, even though the remote transmitter allows this function. The appliance fan is controlled by a fan speed controller (rheostat) or ON/OFF switch depending on the model.

safety decal

This is a copy of the label that accompanies each L234 Gas Insert. We have printed a copy of the contents here for your review. The safety label is located on a plate inside the base of the unit visible when the bottom louver is opened. Ensure that the safety label is attached to the unit.

NOTE: Regency units are constantly being improved. Check the label on the unit and if there is a difference, the label on the unit is the correct one.

For the State of Massachusetts, installation and repair must be done by a plumber or gas fitter licensed in the Commonwealth of Massachusetts.

For the State of Massachusetts, flexible connectors shall not exceed 36 inches in length.

For the State of Massachusetts, the appliance's individual manual shut-off must be a t-handle type valve.

The State of Massachusetts requires the installation of a carbon monoxide alarm in accordance with NFPA 720 and a CO alarm with battery back up in the same room where the gas appliance is installed.

Duplicate Serial number / Copie No de série

521



Intertek
C#4001172

Listed: VENTED GAS FIREPLACE HEATER/FOYER AU GAZ À ÉVACUATION
Certified to/Certifié : ANSI Z21.88-2019 • CSA-2.33-2019
 CSA 2.17-2017
MAY BE INSTALLED IN MANUFACTURED (MOBILE) HOMES AFTER FIRST SALE
 Refer to Intertek's Directory of Building Products for detailed information.
 Pour plus de détails, se reporter au Répertoire des produits de construction de Intertek.

DO NOT REMOVE THIS LABEL / NE PAS ENLEVER CETTE ÉTIQUETTE

521

Serial No. / No de série



Model/Modèle :
L234-NG11

NATURAL GAS FIREPLACE INSERT: MODEL L234-NG11
Factory Equipped For Altitude 0-4500ft. (0-1370m)

Min. Supply Pressure	5" WC	(1.25 kpa)	Pression d'alimentation minimale
Low Setting Man. Pressure	1.6" WC	(0.40 kpa)	Pression de sortie (manifold) - basse
Max. Manifold Pressure	3.5" WC	(0.87 kpa)	Pression de sortie (manifold) - max.
Orifice Size	42	DMS	Taille de l'orifice
Minimum Input	16,500	Btu/h (4.84 kW)	Débit calorifique minimal
Maximum Input	23,500	Btu/h (6.89 kW)	Débit calorifique maximal



Model/Modèle :
L234-LP11

PROPANE GAS FIREPLACE INSERT: MODEL L234-LP11
Factory Equipped For Altitude 0-4500ft. (0-1370m)

Min. Supply Pressure	11" WC	(2.73 kpa)	Pression d'alimentation minimum
Low Setting Man. Pressure	6.4" WC	(1.60 kpa)	Pression de sortie (manifold) - basse
Max. Manifold Pressure	10" WC	(2.49 kpa)	Pression de sortie (manifold) - max.
Orifice Size	54	DMS	Taille de l'orifice
Minimum Input	17,000	Btu/h (4.98 kW)	Débit calorifique minimal
Maximum Input	21,500	Btu/h (6.30 kW)	Débit calorifique maximal

Mantel Clearances / Dégagements manteau

Alcove Width / Largeur alcôve	E 66"	(1524mm)
Alcove Depth / Prof. alcôve	F 36"	(914mm)

Non-Combustible Hearth Extension/ Extension socle non combustible

Hearth Height / Hteur socle	G 1-1/2"	(38mm)
Hearth Width / Largeur socle	H 28"	(711mm)
Hearth Depth / Prof. socle	I 12"	(305mm)

* Alcove side wall must have a min. of 8" clearance on one side. *La paroi latérale de l'alcôve doit avoir un dégagement min. de 8 po par rapport à un côté.



Fan Part No. 910-215/P / Pièce ventilateur n°910-215/P
ELECTRICAL SUPPLY/ALIMENTATION ÉLECTRIQUE:
 115V60HZ less than/Moins de 2 AMP.

Minimum Clearances to Combustibles from Insert/ Dégagements min. des matériaux combustibles à l'encestrable

Side Walls / Parois latérales	*A 8"	(203mm)
Ceiling / Plafond	B 56"	(1422mm)
Min. Mantel Height/Hteur min. manteau	C 21"	(533mm)
Max. Mantel Depth/Prof. max. manteau	D 12"	(914mm)
Alcove Width / Largeur alcôve	E 76"	(1930mm)

FPI Fireplace Products International Ltd., Delta BC, CANADA



MADE IN CANADA / FABRIQUÉ AU CANADA

This appliance must be installed in accordance with local codes, if any; if none, follow the National Fuel Gas Code, ANSI Z223.1, or Natural Gas and Propane Installation Code, CSA B149.1.
 This appliance must be installed in accordance with the Standard CAN/CSA Z240 MH, Mobile Housing, in Canada, or with the Manufactured Home Construction and Safety Standard, Title 24 CFR, Part 3280, in the United States, or when such a standard is not applicable, ANSI/NCSBCS A225.1/NFPA 501A, Manufactured Home Installations Standard.
 This appliance is only for use with the type of gas indicated on the rating plate and may be installed in an aftermarket, permanently located, manufactured (mobile) home where not prohibited by local codes. See owner's manual for details.
 This appliance is not convertible for use with other gases unless a certified kit is used.
WARNING: This fireplace has been converted for use with a gas fireplace insert only and cannot be used for burning wood or solid fuels unless all original parts have been replaced, and the fireplace re-approved by the authority having jurisdiction.
 Installer l'appareil selon les codes ou règlements locaux, ou, en l'absence de tels règlements, selon les codes d'installation ANSI Z223.1, National Fuel Gas Code ou CSA-B149.1 en vigueur.
 Cet appareil doit être installé conformément à la norme CAN/CSA-Z240, Série MM, Maison mobiles ou CAN/CSA-Z240 VC, Véhicules de camping, au Canada ou à la norme 24 CFR Part 3280, Manufactured Home Construction and Safety Standard aux États-Unis. Si ces normes ne sont pas pertinentes, utilisez la norme ANSI/NCSBCS A225.1/NFPA 501A, Manufactured Home Installations Standard.
 Cet appareil doit être utilisé uniquement avec le type de gaz indiqué sur la plaque signalétique. Cet appareil peut être installé dans une maison préfabriquée ou mobile (É.-U. seulement) installée à demeure si les règlements locaux le permettent. Voir le manuel d'utilisation pour plus de renseignements. Cet appareil ne peut pas être utilisé avec d'autres gaz sauf si une trousse de conversion certifiée est utilisée.
AVERTISSEMENT : Ce foyer a été converti pour être utilisé avec un foyer au gaz encastrable et ne peut être utilisé pour brûler du bois ou d'autres combustibles solides à moins que toutes les pièces d'origine aient été remises en place et que le foyer ait été homologué de nouveau par une autorité compétente.

This vented gas fireplace heater is not for use with air filters. Ne pas utiliser de filtre à air avec ce foyer au gaz à évacuation.
 For use with glass doors certified with the appliance only. Pour utilisation uniquement avec les portes en verre certifiées avec l'appareil

For Use Only with Barrier (Part #537-000) Follow installation instructions. Utiliser uniquement avec un écran de protection (pièce n°537-000). Suivre les instructions d'installation.

VENTED GAS FIREPLACE HEATER - NOT FOR USE WITH SOLID FUELS. CATEGORY I./ Foyer au gaz à évacuation - NE PAS UTILISER AVEC UN COMBUSTIBLE SOLIDE. CATÉGORIE I.



Intertek
EPS01189

CSA P.4.1 Fireplace Efficiency (FE) /Efficacité énergétique des foyers (EEF) CSA P.4.1
 Natural Gas / Gaz naturel 63.77%
 Propane Gas / Gaz propane 65.02%

920-067b

Decal Location

Remove the faceplate from the unit. Once the faceplate has been removed, the rating plate will be located below the glass.

DO NOT REMOVE DECAL FROM UNIT.

4 | Liberty® L234-11 Direct Vent Gas Insert

MA Code - CO Detector (for the State of Massachusetts only)

5.08: Modifications to NFPA-54, Chapter 10

(2) Revise 10.8.3 by adding the following additional requirements:

(a) For all side wall horizontally vented gas fueled equipment installed in every dwelling, building or structure used in whole or in part for residential purposes, including those owned or operated by the Commonwealth and where the side wall exhaust vent termination is less than seven (7) feet above finished grade in the area of the venting, including but not limited to decks and porches, the following requirements shall be satisfied:

1. **INSTALLATION OF CARBON MONOXIDE DETECTORS.** At the time of installation of the side wall horizontal vented gas fueled equipment, the installing plumber or gasfitter shall observe that a hard wired carbon monoxide detector with an alarm and battery back-up is installed on the floor level where the gas equipment is to be installed. In addition, the installing plumber or gasfitter shall observe that a battery operated or hard wired carbon monoxide detector with an alarm is installed on each additional level of the dwelling, building or structure served by the side wall horizontal vented gas fueled equipment. It shall be the responsibility of the property owner to secure the services of qualified licensed professionals for the installation of hard wired carbon monoxide detectors

a. In the event that the side wall horizontally vented gas fueled equipment is installed in a crawl space or an attic, the hard wired carbon monoxide detector with alarm and battery back-up may be installed on the next adjacent floor level.

b. In the event that the requirements of this subdivision can not be met at the time of completion of installation, the owner shall have a period of thirty (30) days to comply with the above requirements; provided, however, that during said thirty (30) day period, a battery operated carbon monoxide detector with an alarm shall be installed.

2. **APPROVED CARBON MONOXIDE DETECTORS.** Each carbon monoxide detector as required in accordance with the above provisions shall comply with NFPA 720 and be ANSI/UL 2034 listed and IAS certified.

3. **SIGNAGE.** A metal or plastic identification plate shall be permanently mounted to the exterior of the building at a minimum height of eight (8) feet above grade directly in line with the exhaust vent terminal for the horizontally vented gas fueled heating appliance or equipment. The sign shall read, in print size no less than one-half (1/2) inch in size, "**GAS VENT DIRECTLY BELOW. KEEP CLEAR OF ALL OBSTRUCTIONS**".

4. **INSPECTION.** The state or local gas inspector of the side wall horizontally vented gas fueled equipment shall not approve the installation unless, upon inspection, the inspector observes carbon monoxide detectors and signage installed in accordance with the provisions of 248 CMR 5.08(2)(a)1 through 4.

(b) **EXEMPTIONS:** The following equipment is exempt from 248 CMR 5.08(2)(a)1 through 4:

1. The equipment listed in Chapter 10 entitled "Equipment Not Required To Be Vented" in the most current edition of NFPA 54 as adopted by the Board; and

2. Product Approved side wall horizontally vented gas fueled equipment installed in a room or structure separate from the dwelling, building or structure used in whole or in part for residential purposes.

(c) **MANUFACTURER REQUIREMENTS - GAS EQUIPMENT VENTING SYSTEM PROVIDED.** When the manufacturer of Product Approved side wall horizontally vented gas equipment provides a venting system design or venting system components with the equipment, the instructions provided by the manufacturer for installation of the equipment and the venting system shall include:

1. Detailed instructions for the installation of the venting system design or the venting system components; and

2. A complete parts list for the venting system design or venting system.

(d) **MANUFACTURER REQUIREMENTS - GAS EQUIPMENT VENTING SYSTEM NOT PROVIDED.** When the manufacturer of a Product Approved side wall horizontally vented gas fueled equipment does not provide the parts for venting the flue gases, but identifies "special venting systems", the following requirements shall be satisfied by the manufacturer:

1. The referenced "special venting system" instructions shall be included with the appliance or equipment installation instructions; and

2. The "special venting systems" shall be Product Approved by the Board, and the instructions for that system shall include a parts list and detailed installation instructions.

(e) A copy of all installation instructions for all Product Approved side wall horizontally vented gas fueled equipment, all venting instructions, all parts lists for venting instructions, and/or all venting design instructions shall remain with the appliance or equipment at the completion of the installation.

dimensions

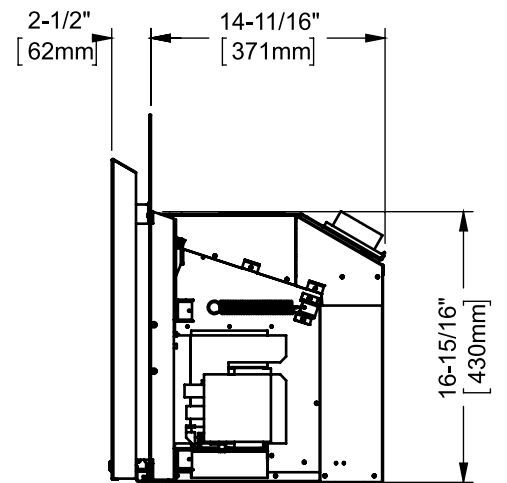
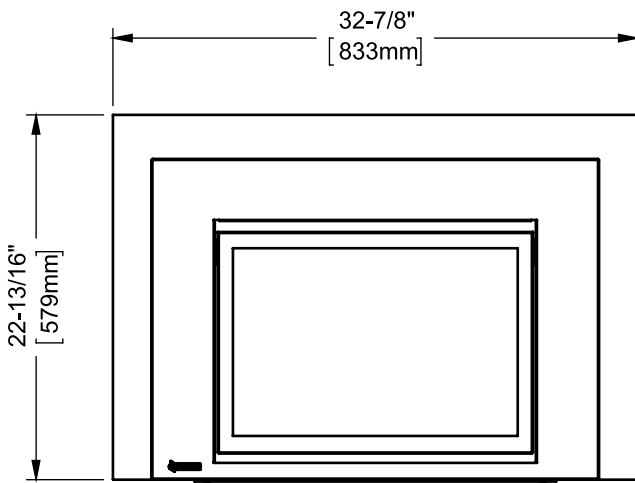
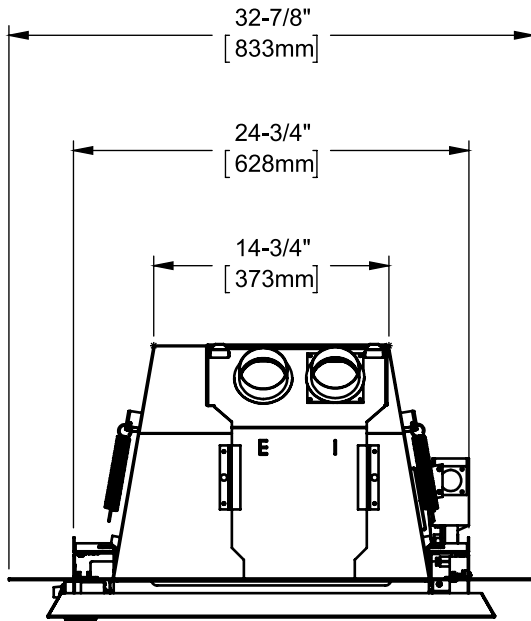

Shown with Low Profile Faceplate

ALL PICTURES / DIAGRAMS SHOWN THROUGHOUT THIS MANUAL ARE FOR ILLUSTRATION PURPOSES ONLY. ACTUAL PRODUCT MAY VARY DUE TO PRODUCT ENHANCEMENTS.

Gas Installation Checklist

This general checklist does not contain all pertinent installation details or specifics and does not supersede the guidelines in this manual. Your Regency dealer/installer should use it in conjunction with manual instructions. Please follow all local codes and jurisdictions in authority.

Customer: _____	Date Installed: _____
Install Address: _____	Location of Fireplace: _____
Serial No: _____	Installer: _____
Model No: _____	
Site Requirements	YES NO
If applicable, are the insulation, vapour barrier, and drywall present if installed on an outside wall or chase?	
Does the area have a solid continuous base to support the unit?	
Will the area accommodate the size of the appliance and all clearances?	
Are the gas and electrical roughed into the area where the unit is being installed?	
In City & Grandview series cool wall applications, is the chase enclosure sealed to prevent heat from escaping? All hot air from the unit must exit via the mandatory ventilation openings.	
In City & Grandview applications, Is the chase enclosure vented with the mandatory heat ventilation openings? See manual for details.	
If applicable, is the masonry/factory built freplace in its original condition with no modifications?	
If applicable, have the hearth requirements been met?	
Unit Setup	YES NO
If applicable, are the standoffs and top nailing flange extensions installed and at the correct depth to accommodate finishing material? See manual for details.	
If applicable, is the fireplace level and secured, meeting framing clearances? See manual for details.	
If applicable, is the unit converted to top or rear vent per manual instructions, and the insulation discarded?	
Venting	YES NO
Are the venting components approved for the unit installed?	
Does the venting configuration comply with venting diagrams?	
Is venting installed and secured, and are clearances for the vent pipe and termination cap maintained?	
If applicable, was a 1/4" rise maintained for every foot of horizontal run?	
Was the termination installed and sealed?	
Is the direct vent termination at the highest point in the vent assembly?	
If applicable, are both chimney liners continuous from flue collars to termination?	
Electrical and Wiring	YES NO
Is the appliance connected to the household's 110/120v per local codes? Check local codes for receptacle placement.	
Were the connections in the fireplace tested with a circuit tester?	
Is the appliance properly grounded?	
If applicable, is the supplied electrical/gang box affixed to the wall to facilitate the mounting of the receiver/battery box ?	
If applicable, is all electrical, Ethernet, HDMI, networking, optical, wire/cables, conduits, etc. run through the wood or steel stud work as wires/cables of any kind cannot be exposed directly above or over the fireplace?	
Gas	YES NO
Does the supply pressure meet the requirements shown on the rating plate?	
Was a conversion performed?	
Was a leak check performed and manifold pressures verified?	

installation

Is the shut-off valve installed and easily accessible to the customer?		
Finishing	YES	NO
If applicable, is only noncombustible material installed in the noncombustible areas?		
Do clearances meet installation and manual requirements?		
Do the mantels and/or projections comply with the installation manual?		
If applicable, was the solid fuel fireplace warning plate installed?		
Is the chase enclosure fully open the full width, height and depth above the fireplace as per the requirements noted in the framing section?		
Appliance Media Setup	YES	NO
Do commands from the remote or wall switch light the pilot and main burner?		
Are the burner media/log set, glass door, and screen installed per instructions in the manual?		
Was the air shutter on the proper setting after running the unit for 20 minutes?		
If applicable, were the surround and trims installed according to the manual?		
Was the operation of the fan, lights (if installed), and flame modulation checked?		
Customer Tutorial and Presentation	YES	NO
Is the customer confident operating the new gas appliance and aware of all the features on the remote?		
Confirm that the rating and lighting plates are attached to the appliance. Do not remove.		
Was the customer informed of the location of the rating and lighting plates?		
Was accessing unit controls in a power outage explained to the customer?		
Are the model and serial numbers and the date of installation of the unit written in the manual and on the checklist?		
Were the warranty and unit registration reviewed with the customer?		
Comments:		

For Your Safety

This appliance requires air for proper combustion. Always provide adequate combustion and ventilation air. Follow instructions and information in CSA B149.1 (in Canada) or the National Fuel Gas Code ANS Z223.1/NFPA (in the USA), regarding requirements for combustion and ventilation air.

INSTALLATION AND REPAIR SHOULD BE DONE BY AN AUTHORIZED SERVICE PERSON. THE APPLIANCE SHOULD BE INSPECTED BEFORE USE AND AT LEAST ANNUALLY BY A PROFESSIONAL SERVICE PERSON. MORE FREQUENT CLEANING MAY BE REQUIRED DUE TO EXCESSIVE LINT FROM CARPETING, BEDDING MATERIAL, ETC. IT IS IMPERATIVE THAT CONTROL COMPARTMENTS, BURNERS AND CIRCULATING AIR PASSAGEWAYS OF THE APPLIANCE BE KEPT CLEAN.

DUE TO HIGH TEMPERATURES, THE APPLIANCE SHOULD BE LOCATED OUT OF TRAFFIC AND AWAY FROM FURNITURE AND DRAPERIES.

WARNING: FAILURE TO INSTALL THIS APPLIANCE CORRECTLY WILL VOID YOUR WARRANTY AND MAY CAUSE A SERIOUS HOUSE FIRE.

CHILDREN AND ADULTS SHOULD BE ALERTED TO THE HAZARDS OF HIGH SURFACE TEMPERATURES, ESPECIALLY THE FIREPLACE GLASS, AND SHOULD STAY AWAY TO AVOID BURNS OR CLOTHING IGNITION.

YOUNG CHILDREN SHOULD BE CAREFULLY SUPERVISED WHEN THEY ARE IN THE SAME AREA AS THE APPLIANCE. TODDLERS, YOUNG CHILDREN AND OTHERS MAY BE SUSCEPTIBLE TO ACCIDENTAL CONTACT BURNS. A PHYSICAL BARRIERS IS RECOMMENDED IF THERE ARE AT RISK INDIVIDUAL IN THE HOUSE. TO RESTRICT ACCESS TO A FIREPLACE OR STOVE, INSTALL AN ADJUSTABLE SAFETY GATE TO KEEP TODDLERS, YOUNG CHILDREN AND OTHER AT RISK INDIVIDUALS OUT OF THE ROOM AND AWAY FROM HOT SURFACES.

CLOTHING OR OTHER FLAMMABLE MATERIAL SHOULD NOT BE PLACED ON OR NEAR THE APPLIANCE.

A BARRIER DESIGNED TO REDUCE THE RISK OF BURNS FROM THE HOT VIEWING GLASS IS PROVIDED WITH THIS APPLIANCE AND SHALL BE INSTALLED FOR THE PROTECTION OF CHILDREN AND OTHER AT-RISK INDIVIDUALS.

IF THE BARRIER BECOMES DAMAGED, THE BARRIER SHALL BE REPLACED WITH THE MANUFACTURER'S BARRIER FOR THIS APPLIANCE.

ANY SAFETY SCREEN, GUARD, OR BARRIER REMOVED FOR SERVICING AN APPLIANCE MUST BE REPLACED PRIOR TO OPERATING THE APPLIANCE.

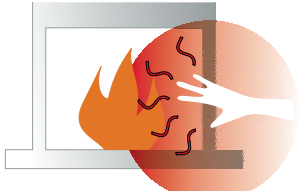

WARNING: Cancer and Reproductive Harm
www.P65Warnings.ca.gov
919-874

Lighting Procedure

IMPORTANT: The remote control system supplied with this appliance has several options for starting/operating the appliance using the battery holder and ON/OFF key on the handheld transmitter.

Prior to operating this appliance, please read the remote control operating instructions (packaged with remote control) to understand how to operate this remote control system.

Important: If the pilot does not hold, turn pilot knob to "OFF" position. Wait 5 minutes to clear gas. If you smell gas - STOP! Follow the safety information above. If you don't smell gas, repeat steps 1-6.

1. Push in gas control knob slightly and turn to "PILOT" position.
2. Push in control knob all the way and hold in until the pilot lights up. Continue to hold the control knob in until a faint buzzer sound can be heard for 4 seconds informing the operator that the knob can now be released. Release knob.
3. Push in gas control knob slightly and turn to "ON" position.
4. Ensure the receiver is in the remote position.
5. Press and release the ON/OFF button on the remote handheld transmitter. An audible beep should be heard from the receiver (see diagram 1). Ensure the receiver is in the remote position.



Diagram 1
Remote shown in Manual Mode on Hi

6. The unit will turn on.

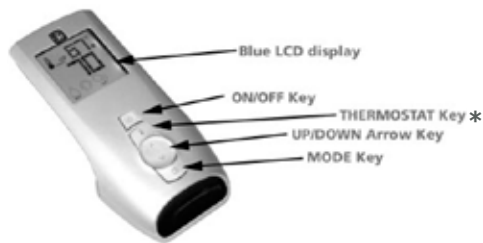

Note: May not be exactly as shown as hand-held may be silver or black.

Shutdown Procedure

1. Press "OFF" on the remote or slide receiver switch from remote to "OFF".
2. Turn the gas control knob to the "OFF" position to turn off the pilot. Pilot may be shut off during prolonged non-use periods to conserve fuel.
3. If service is to be performed - you must disconnect power and shut off gas to the unit.

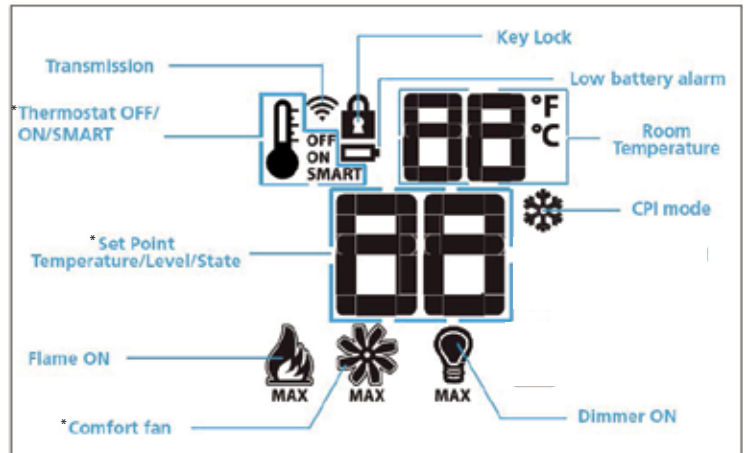

* Not offered on all models.

See remote control instructions for details.

Copy of the Lighting Plate Instructions

FOR YOUR SAFETY READ BEFORE LIGHTING
POUR VOTRE SÉCURITÉ – À LIRE AVANT LA MISE EN MARCHÉ

WARNING: If you do not follow these instructions exactly, a fire or explosion may result causing property damage, personal injury or loss of life. Improper installation, adjustment, alteration, service or maintenance can cause injury or property damage. Refer to the owner's information manual provided with this appliance. For assistance or additional information consult a qualified installer, service agency or gas supplier.

AVERTISSEMENT. Quiconque ne respecte pas à la lettre les instructions dans la présente notice risque de déclencher un incendie ou une explosion entraînant des dommages, des blessures ou la mort. Une installation, d'ajustement, de modification, de service ou d'entretien peut provoquer des blessures ou des dommages matériels. Reportez-vous au manuel du propriétaire fourni avec cet appareil. Pour obtenir de l'aide ou des informations supplémentaires consulter un installateur qualifié, une agence de service ou fournisseur de gaz.

- A) This appliance has a pilot that must be lighted by hand. When lighting the pilot, follow these instructions exactly.
- B) **BEFORE LIGHTING** smell all around the appliance area for gas. Be sure to smell next to the floor because some gas is heavier than air and will settle on the floor.
- WHAT TO DO IF YOU SMELL GAS**
- Do not try to light any appliance.
 - Do not touch any electric switch, do not use any phone in your building.
 - Leave the building immediately.
 - Immediately call your gas supplier from a neighbours phone. Follow the gas supplier's instructions.
 - If you cannot reach your gas supplier, call the fire department.
- C) Use only your hand to push in or turn the gas control knob. Never use tools. If the knob will not push in or turn by hand, do not try to repair it; call a qualified service technician. Force or attempted repair may result in a fire or explosion.
- D) Do not use this appliance if any part has been under water. Immediately call a qualified service technician to inspect the appliance and replace any part of the control system and any gas control which has been underwater.
- A) Cet appareil est muni d'une veilleuse qui doit être allumée manuellement. Respectez les instructions ci-dessous à la lettre.
- B) **AVANT LA MISE EN MARCHÉ,** reniflez tout autour de l'appareil pour déceler une odeur de gaz. Reniflez au niveau du plancher, car certains gaz sont plus lourds que l'air et peuvent s'accumuler au niveau du sol.

QUE FAIRE SI VOUS SENTEZ UNE ODEUR DE GAZ :

- Ne tentez pas d'allumer l'appareil
 - Ne touchez à aucun interrupteur; n'utilisez pas de téléphones se trouvant dans le bâtiment.
 - Sortez du bâtiment immédiatement
 - Appelez immédiatement votre fournisseur de gaz depuis un téléphone extérieur. Suivez les instructions du fournisseur.
 - Si vous ne pouvez pas rejoindre le fournisseur, appelez le service incendie.
- C) Ne poussez ni ne tournez la manette d'admission du gaz qu'à la main. Ne jamais employer d'outil à cette fin. Si la manette reste coincée, ne tentez pas de la réparer, appelez un technicien qualifié. Quiconque tente de forcer la manette ou de la réparer peut provoquer une explosion ou un incendie.
- D) N'utilisez pas cet appareil s'il a été plongé dans l'eau, même partiellement. Faites inspecter l'appareil par un technicien qualifié et remplacez tout élément du système de contrôle ou de commande qui a été plongé dans l'eau.

CAUTION: Hot while in operation. Do not touch. Severe burns may result. Due to high surface temperatures keep children, clothing and furniture, gasoline and other liquids having flammable vapors away. Keep burner and control compartment clean. See installation and operating instructions accompanying appliance.

ATTENTION : Surfaces chaudes lorsque l'appareil est en marche. Ne pas toucher. Risque de brûlures graves. En raison des températures élevées, les enfants, les vêtements et le mobilier, le carburant et tout autre liquide aux vapeurs inflammables doivent être tenus éloignés de l'appareil. Nettoyer régulièrement le brûleur et le compartiment des commandes. Voir les consignes d'installation et d'utilisation fournies avec l'appareil.

LIGHTING INSTRUCTIONS / CONSIGNES D'ALLUMAGE
1) STOP! Read the safety information above on this label.

This appliance is equipped with an on-demand pilot that shuts off after seven days.

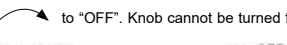
- 2) Push in gas control knob slightly and turn clockwise  to "OFF". Knob cannot be turned from "PILOT" to "OFF" unless knob is pushed in slightly. Do not force.



- 3) Wait five (5) minutes to clear out any gas. If you then smell gas STOP! Follow step "B" in the Safety Information above on this label. If you don't smell gas, go to the next step.

- 4) Push in gas control knob slightly and turn counterclockwise  to "PILOT" position.

- 5) Push in control knob all the way and hold in until the pilot lights. Continue to hold the control knob in for about 30 seconds after the pilot lights. Release the knob.

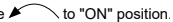
- 6) Push in gas control knob slightly and turn counterclockwise  to "ON" position.

- 7) Turn on the flame switch.

1) STOP ! Lire les instructions de sécurité sur la portion supérieure de cette étiquette.

Cet appareil est équipé d'une veilleuse sur demande qui s'éteint après sept jours.

- 2) Enfoncer légèrement le bouton de commande de gaz et tournez dans le sens horaire  en position OFF. Le bouton ne peut pas être tourné du PILOT à OFF à moins que le bouton soit enfoncé légèrement. Ne forcez pas.

- 3) Attendre cinq (5) minutes pour laisser échapper tout le gaz. Si vous sentez une odeur de gaz, ARRÊTEZ! Passez à l'étape "B" des instructions de sécurité sur la portion supérieure de cette étiquette. S'il n'y a pas d'odeur de gaz, passez à l'étape suivante.

- 4) Enfoncer légèrement le bouton de commande de gaz et tournez dans le sens antihoraire  en position PILOT.

- 5) Poussez le bouton de commande de gaz à fond et le maintenir enfoncé jusqu'à ce que la veilleuse s'allume. Maintenir le bouton de commande de gaz enfoncé pendant environ 30 secondes après l'allumage de la veilleuse. Relâcher le bouton de commande de gaz.

- 6) Enfoncer légèrement le bouton de commande de gaz et tourner dans le sens antihoraire  en position 'ON'.

- 7) Actionner l'interrupteur de flamme.

TO TURN OFF GAS TO APPLIANCE / POUR COUPER LE GAZ AU NIVEAU DE L'APPAREIL

- 1) Turn off the flame switch.
- 2) Push in the gas control knob slightly and turn  clockwise to "OFF". Do not force.

- 3) Turn off all electric power to the appliance if service is to be performed.

You may shut off the pilot during prolonged non use periods to conserve fuel.

- 1) Fermer l'interrupteur de flamme.
- 2) Enfoncer légèrement le bouton de commande de gaz et tournez dans le sens horaire  en position OFF. Ne pas forcer.

- 3) Avant d'effectuer des opérations d'entretien, couper l'alimentation électrique de l'appareil.

Pour économiser le carburant, vous pouvez éteindre la veilleuse lorsque l'appareil reste longtemps inutilisé.

DO NOT REMOVE THIS INSTRUCTION PLATE

NE PAS ENLEVER CETTE ÉTIQUETTE D'INSTRUCTIONS

920-438

Proflame I Remote Control Operating Instructions

IMPORTANT: The Proflame Transmitter 1 is an integrated part of the Proflame 1 System, which consists of these elements:

- Proflame 1 Transmitter, to be used in conjunction with:
- Integrated Fireplaces Control (Proflame 1 DFG)

The Proflame 1 Transmitter provides for controlling the following hearth appliance functions:

1. Main Burner On/Off
2. Main Burner flame modulation (6 levels)
3. Thermostat and Smart thermostat functions
4. Accent light modulation (6 levels)**
5. Comfort Fan speed modulation (6 levels)**

** This feature is not available on all models.

The Proflame Transmitter uses a streamline design with a simple button layout and informative LCD display (Fig. 1). A Mode Key is provided to index between the features and a Thermostat Key is used to turn on/off or index through Thermostat functions (Fig. 1 & 2). Additionally, a Key Lock feature is provided (Fig. 22).



Figure 1: Proflame Transmitter

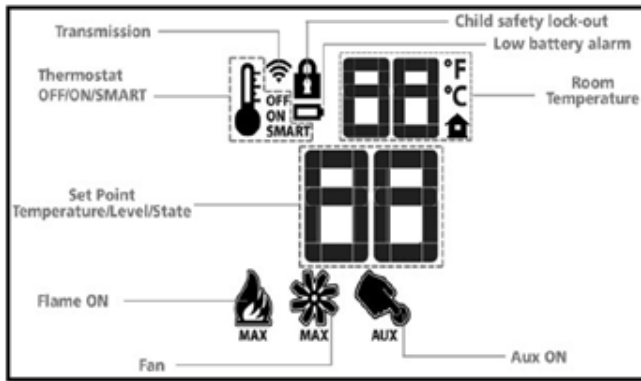

Figure 2: Transmitter LCD Display

Note: May not be exactly as shown as hand-held may be silver or black.

TECHNICAL DATA REMOTE CONTROL	
Supply Voltage	4.5V (three 1.5V AAA batteries)
Ambient temperature ratings	0 - 50°C (32 - 122°F)
Radio Frequency	315 MHZ

WARNING: THE TRANSMITTER AND RECEIVER ARE RADIO FREQUENCY DEVICES. PLACING THE RECEIVER IN OR NEAR METAL MAY SEVERELY REDUCE THE SIGNAL RANGE.

ATTENTION!

- Turn "OFF" the main gas supply of the appliance during installation or maintenance of the Receiver device.
- Turn "OFF" main gas supply to the appliance prior to removing or reinserting the batteries.
- In case of remote control malfunction, turn off the IFC device using the "ON/OFF" main switch.
- For installation / maintenance, switch off the IFC device removing main power supply plug.

OPERATING PROCEDURE

Pairing the remote control to remote receiver/ battery holder (if required)

Install the 4 AA batteries into the receiver battery bay. Note the polarity of the battery and insert into the battery bay as indicated on the battery cover (+/-). Place the 3 position slider switch in the "Remote" position. Press the PRG button located on the top right hand corner of receiver, see the receiver instruction(*). The Receiver will "beep" three (3) times to indicate that it is ready to synchronize with a Transmitter. Install the 3 AAA type batteries in the Transmitter battery bay, located on the base of the Transmitter (Fig. 3). With the batteries already installed in the Transmitter, push the On button. The Receiver will "beep" four times to indicate the Transmitter's command is accepted and sets to the particular code of that Transmitter. The system is now initialized.

(*) The receiver may be independent or integral to the IFC hearth appliance control module. The receiver instruction may not be independent when part of the IFC.



Figure 3: Battery Compartment

Note: Only use regular alkaline batteries. Do not use rechargeable or lithium batteries.

Temperature indication Display

With the system in the "OFF" position, press the Thermostat Key and the Mode Key at the same time. Look at the LCD screen on the transmitter to verify that a C or F is visible to the right of the room temperature display (Figures 4 & 5).

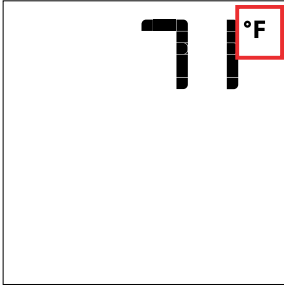

Figure 4: Remote Control display in Fahrenheit.

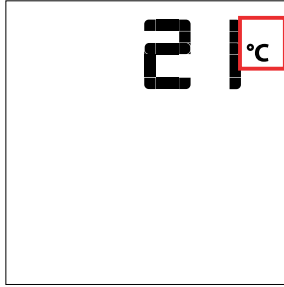

Figure 5: Remote Control display in Celsius.

Turn on the Appliance

With the system OFF, press the ON/OFF Key on the Transmitter. The Transmitter display will show some other active Icons on the screen. At the same time the Receiver will activate the appliance. A single "beep" from the Receiver will confirm reception of the command.

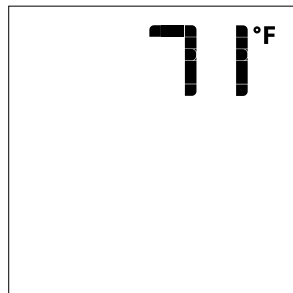

Figure 6: Remote Control display

Turn off the Appliance

With the system ON, press the ON/OFF Key on the Transmitter. The Transmitter LCD display will only show the room temperature (Fig. 6). At the same time the Receiver will turn off the appliance. A single "beep" from the Receiver confirms reception of the command.

Remote-Flame Control

The Proflame has six (6) flame levels. With the system on, and the flame level at the maximum in the appliance, pressing the Down Arrow Key once will reduce the flame height by one step until the flame is turned off. The Up Arrow Key will increase the flame height each time it is pressed. If the Up Arrow Key is pressed while the system is on but the flame is off, the flame will come on in the high position (Fig. 7 & 8). A single "beep" will confirm reception of the command.

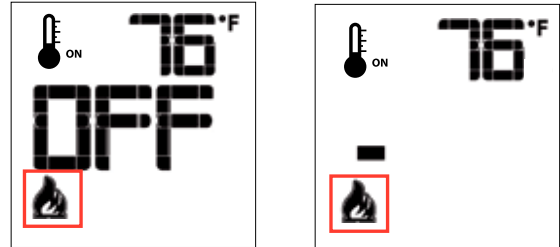

Fig. 7

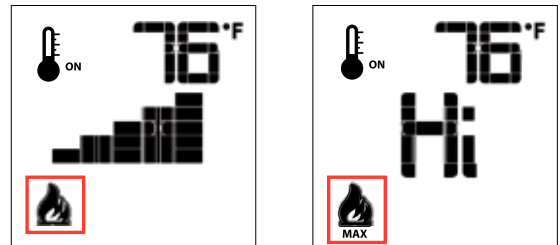

Fig. 8

Room Thermostat (Transmitter Operation)

The Remote Control can operate as a room thermostat. The thermostat can be set to a desired temperature to control the comfort level in a room. To activate this function, press the Thermostat Key (Fig. 1). The LCD display on the Transmitter will change to show that the room thermostat is "ON" and the set temperature is now displayed (Fig. 9). To adjust the set temperature, press the Up or Down Arrow Keys until the desired set temperature is displayed on the LCD screen of the Transmitter.

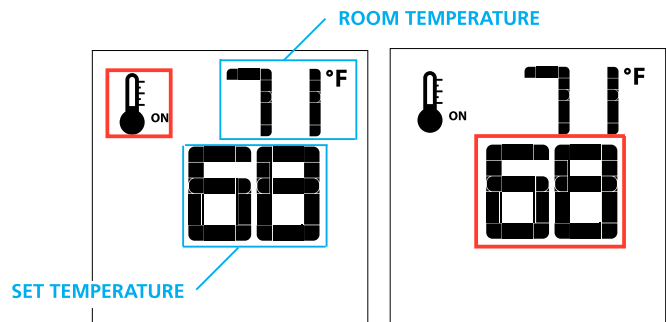

Figure 9

Figure 10

Smart Thermostat (Transmitter Operation)

The Smart Thermostat function adjusts the flame height in accordance to the difference between the set point temperature and the actual room temperatures. As the room temperature gets closer to the set point the Smart Function will modulate the flame down.

To activate this function, press the Thermostat Key (Fig. 1) until the word "SMART" appears to the right of the temperature bulb graphic (Fig. 11). To adjust the set temperature, press the Up or Down Arrow Keys until the desired set temperature is displayed on the LCD screen of the Transmitter (Fig. 12).

Note. When Smart Thermostat is activated, manual flame height adjustment is disabled.

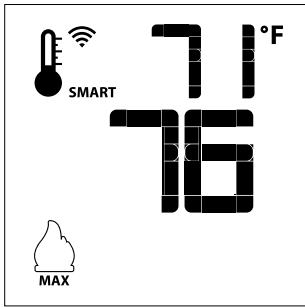

Figure 11: Smart Flame Function

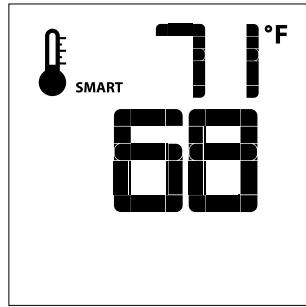

Figure 12

Fan Speed Control**

If the appliance is equipped with a hot air circulating fan, the speed of the fan can be controlled by the Proflame system. The fan speed can be adjusted through six (6) speeds. To activate this function use the Mode Key (fig.1) to index to the fan control icon (Fig. 13). Use the Up/Down Arrow Keys (fig.1) to turn on, off or adjust the fan speed (fig. 14). A single "beep" will confirm reception of the command.



Figure 13

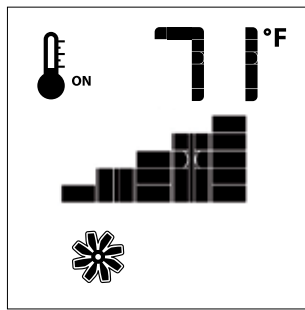

Figure 14

Remote dimmer control (Light)**

The auxiliary function controls the AUX power outlet by the dimmable light control. To activate this function use the Mode Key (fig. 1) to index to the AUX icon (fig. 15 & 16).

The intensity of the output can be adjusted through six (6) levels. Use the Up/Down Arrow Keys (fig.1) adjust the output level (fig. 16). A single "beep" will confirm reception of the command.

Note: This function is available only with the IFC Control Module.

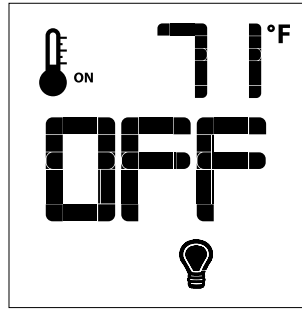

Figure 15

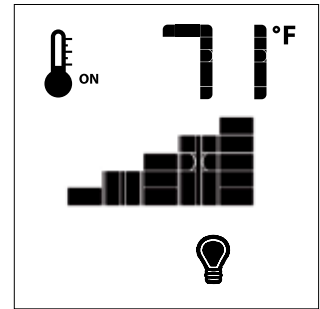

Figure 16

KEY LOCK

This function will lock the keys to avoid unsupervised operation.

To activate this function, press the MODE and UP Keys at the same time (fig. 21).

To de-activate this function, press the MODE and UP Keys at the same time.

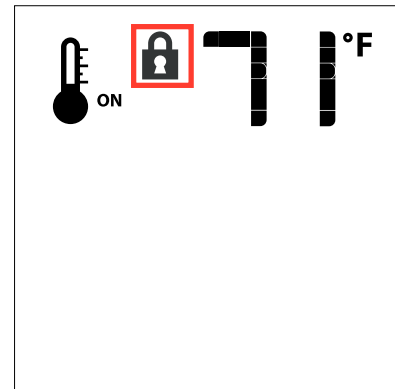

Figure 18

LOW BATTERY POWER DETECTION

Transmitter

The life span of the remote control batteries depends on various factors: quality of the batteries used, the number of ignitions of the appliance, the number of changes to the room thermostat set point, etc. When the Transmitter batteries are low, a Battery Icon will appear on the LCD display of the Transmitter (Fig. 22) before all battery power is lost. When the batteries are replaced this Icon will disappear.

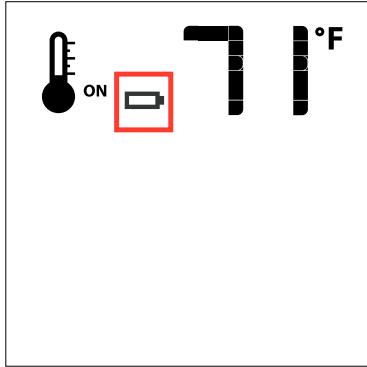

Figure 19

ENABLE / DISABLE functions on the Proflame I remote only.

1. Remove one battery from the remote.
2. Press and hold both the **ON/OFF** and the **MODE** button at the same time.
3. Reinstall the battery (removed in Step 1) while still holding both buttons (keep holding both buttons and once all batteries are installed then release the **MODE** button only).
4. The screen will show **CFG**.
5. Use the up or down arrow button to program out the function on the remote.

Proflame I Remote Receiver Battery Replacement

Remote Receiver Battery Replacement

How to replace/add the batteries on remote receiver.

Note: 4 AA batteries are mandatory in the remote receiver to operate appliance when using remote control.

STEP 1

Move both the left/right slides as shown below.

The battery compartment will be pushed out slightly, to allow to easily extract it

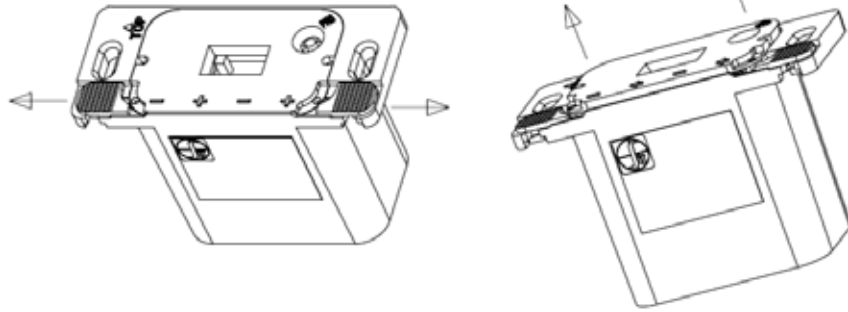

STEP 2

Extract the battery compartment from the remote receiver/battery holder

Replace 4 x AA batteries and insert the battery compartment back into remote receiver/battery holder

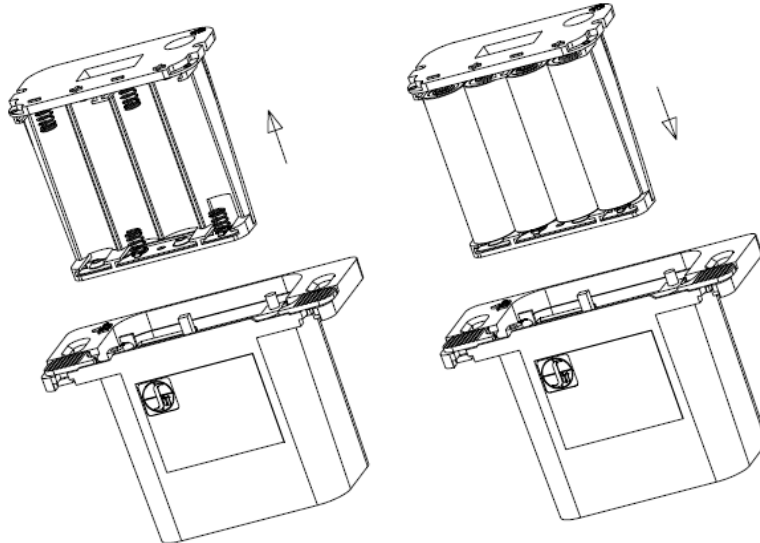

STEP 3

Keeping the battery compartment pressed in, close the left slide

Close the right slide

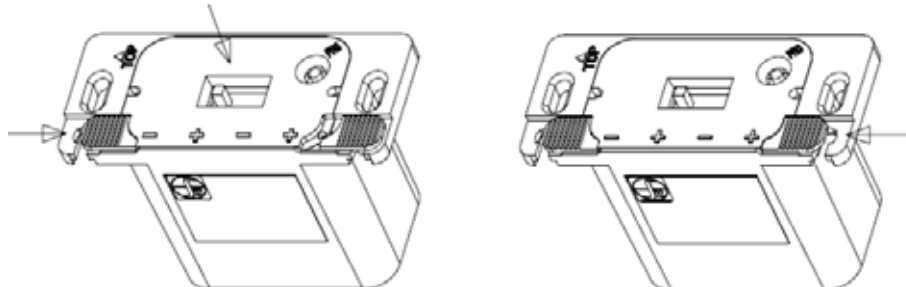

STEP 4 Reinstall wall cover plate with 2 Phillips head screws.

Important Message

SAVE THESE INSTRUCTIONS

The Regency Direct Vent Gas Insert must be installed in accordance with these instructions. Carefully read all the instructions in this manual first. Consult the building authority having jurisdiction to determine the need for a permit prior to starting the installation.

NOTE: Failure to follow the instructions could cause a malfunction of the heater which could result in death, serious bodily injury, and/or property damage. Failure to follow these instructions may also void your fire insurance and/or warranty.

Gas Pressure Testing

The appliance must be isolated from the gas supply piping system by closing its individual manual shut off valve during any pressure testing of the gas supply piping system at test pressures equal to or less than 1/2 psig. (3.45 kPa).

Specifications

At pressures over 1/2 psig, the pipe to the unit must be disconnected.

Gas Input Capacity:

Natural Gas	23,500 Btu/h
Propane	21,500 Btu/h

Min. Input:

Natural Gas	16,500 Btu/h
Propane	17,000 Btu/h

Fuels: Approved for use with both natural gas, and propane. Approved as is for use at 0' to 4,500' (0-1370m).

Electrical: 120V A.C. system.

Circulation Fan: Variable speed, 127 CFM.

Log Set: Ceramic fibre, 6 per set.

Vent System: 3" (76mm) (intake, exhaust) co-linear aluminum flex or 2" (51mm) intake with 3" (76mm) exhaust.

General Safety Information

- 1) The appliance installation must conform with local codes or in the absence of local codes, with CSA B149.1 (in Canada) or the National Fuel Gas Code ANSI Z223.1 NFPA 54 in the U.S.A. This appliance should be installed by a qualified gas fitter technician only.
- 2) **Installation and repair should be done by a qualified service person.**
- 3) **The appliance should be inspected before use and at least annually by a professional service person. More frequent cleaning may be required due to excessive lint from carpeting, bedding material, animal hair, etc. It is imperative that control compartments, burners and circulating air passageways of the appliance be kept clean.**
- 4) See general construction and assembly instructions. This appliance may only be installed in a vented, non combustibile fireplace.
- 5) This appliance is Listed for bedroom installations when used with a Listed Millivolt Thermostat. Some areas may have further requirements, check local codes before installation.
- 6) Always connect this appliance to a venting system that is run (or routed) to the outside of the building envelope. Never vent to another room or inside a building. Make sure that the vent is properly sized and is of adequate height to provide the proper draft.
- 7) Inspect the venting system annually for blockage and any signs of deterioration.
- 8) Any glass removed for servicing must be replaced prior to operating the appliance.
- 9) **WARNING: Failure to position the parts in accordance with the diagrams in this manual or failure to use only parts specifically approved with this appliance may result in property damage or personal injury.**
- 10) To prevent injury, do not allow anyone who is unfamiliar with the operation to use the fireplace.

Installer must mechanically attach the supplied label to the inside of the firebox of the fireplace into which the gas fireplace insert is installed.

"WARNING: This fireplace has been converted for use with a gas fireplace insert only and cannot be used for burning wood or solid fuels unless all original parts have been replaced, and the fireplace re-approved by the authority having jurisdiction."

installation

Gas Pressure Testing

The appliance must be isolated from the gas supply piping system by closing its individual manual shut-off valve during any pressure testing of the gas supply piping system at test pressures equal to or less than 1/2 psig. (3.45 kPa).

Installation Into A Solid Fuel Burning Fireplace or Factory Built Fireplace

The L234 Gas Inserts have been tested and approved to be vented into any masonry fireplace or approved solid fuel burning factory built fireplace that will allow the insert to physically fit into the firebox. Refer to "Minimum Fireplace Dimensions" section for minimum fireplace clearances.

If the factory built fireplace* height is too low for your insert, you may remove the smoke baffle plate, damper, refractory (firebricks), glass doors, screen rails, screen mesh and log grates from the factory built fireplace as long as these items are saved and are reinstalled in the event that the insert is removed. The fireplace flue damper can be fully blocked open or removed for installation of the gas fireplace insert.

Smoke shelves, shields and baffles may be removed if attached by mechanical fasteners. If any part is removed it must not weaken the structural integrity of the factory built fireplace.

The fireplace and fireplace chimney must be clean and in good working order and constructed of non-combustible materials.

The surround panels should not seal ventilation openings on the fireplace.

Chimney clean outs should fit properly.

NOTE: Any alterations made to the listed solid fuel burning factory built fireplace may void the listing of the fireplace.

Cutting any sheet metal part of the fireplace, in which the gas fireplace insert is to be installed, is prohibited.

*Check with your local inspector before commencing with this installation.

Installer must mechanically attach the supplied label to the inside of the firebox of the fireplace into which the gas fireplace insert is installed.

"WARNING: This fireplace has been converted for use with a gas fireplace insert only and cannot be used for burning wood or solid fuels unless all original parts have been replaced, and the fireplace re-approved by the authority having jurisdiction."

Before You Start

Safe installation and operation of this appliance requires common sense, however, we are required by the Canadian Safety Standards and ANSI Standards to make you aware of the following:

Factory-Built (Metal) Wood Burning Fireplace Requirements

NOTE: Any parts that are removed must be removed in a way that would allow them to be re-installed if the insert is ever removed (removal of rivets or screws is acceptable).

To reference parts—see illustration below.

Must be removed:

- 1 - Damper
- 2 - Grate (with log set)

May be removed (if applicable):

- 3 - Smoke shelf
- 4 - Internal baffles
- 5 - Screen
- 6 & 7 - Masonry lining or refractory
- 8 - Metal or glass doors

The fireplace must be permanently marked to indicate that it has been altered and is no longer suitable for burning solid fuel (wood), unless the removed parts are re-installed. Cutting of any sheet metal parts is prohibited.

May be removed (in certain cases):

- 9 - Metal floor of the firebox

10 - The insulation and any structured rigid frame members must not be removed or altered (side and top of door frame, side and top of the face of the fireplace, metal sides, etc.).

If the factory-built fireplace has no gas access hole(s) provided, an access hole of 1.5 inch (37.5 mm) or less may be drilled through the lower sides or bottom of the firebox in a proper workmanship like manner. This access hole must be plugged with non-combustible insulation after the gas supply line has been installed.

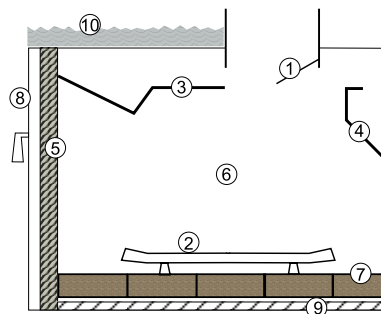

CAUTION:

Firebox floor removal is not covered under the appliance safety standard (ANSI Z21.88, CSA 2.33) used in the safety certification of this appliance. The Intertek safety certification does not apply to this method of installation. Before installing the appliance using this method, contact the Authority Having Jurisdiction to determine if this installation is acceptable in your area. The sheet metal base of the fireplace must be left in place and a minimum 1/2" cement board sheet placed under the entire length and width of the appliance.

11 - Due to high temperatures, the appliance should be located out of high traffic areas and away from furniture and draperies. Children and adults should be alerted to the hazards of high surface temperatures, especially the fireplace glass, and should stay away to avoid burns or clothing ignition. Young children should be carefully supervised when they are in the same room as the appliance. Clothing or other flammable material should not be placed on or near the appliance.

Emissions from burning wood or gas could contain chemicals known to the State of California to cause cancer, birth defects or other reproductive harm.

Installation Checklist

Before installing vent system ensure that the damper plate is open and secure to prevent the damper plate from falling down and crushing the liner.

The Regency Gas Insert is installed as listed below.

- 1)** Check all clearances to combustibles. Refer to the following sections where applicable:
 - a. Minimum Clearances to Combustibles.
 - b. Combustible Mantel Clearances
 - c. Mantel Clearances
- 2)** Make the gas connection. Refer to the "Gas Connection" section.
- 3)** Install the 3" x 3" or 3" x 2" flue liner to the sliding connector plate. Refer to the "Flue Liner Installation" section.
- 4)** Slide the unit half way into the fireplace.
- 5)** Pull the vent connector plate through the tapered brackets and fasten to the front plate. Refer to the "Flue Liner Installation" section.
- 6)** Install 4AA batteries into receiver. Hook receiver to wire marked receiver, this will enable operation of the appliance manually when position in "ON" position.
Note: Batteries are required in both remote receiver (4 x AA Batteries) & remote hand held (3 x AAA batteries) in order to operate appliance using the remote control.
- 7)** Slide the unit fully into the fireplace.
- 8)** Test gas pressure, refer to the "Gas Pipe Pressure Testing" section. Check aeration system, refer to "Gas Insert Aeration Systems" section.

- 9)** Install standard and optional features. Refer to the following sections where applicable:
 - a. Brick Panels
 - b. Log Installation
 - c. Faceplate
 - d. Optional Hearth Trim
 - e. Remote Control
 - f. Wall Thermostat

10) Final check. Refer to the "Final Check" section. Before leaving this unit with the customer, the installer must ensure that the appliance is firing correctly. This includes:

- a)** Clocking the appliance to ensure the correct firing rate.
- b)** Adjusting the primary air, if required, to ensure that the flame does not carbon. Refer to the "Gas Insert Aeration System" section.
- c)** Ensuring that the appliance is venting correctly.

Materials Required

No electrical power supply is required for the gas control to operate. A 120 Volt AC power cord is hooked up to the fan. Plug the 3 wire cord into a suitable receptacle. **Do not cut the ground terminal off under any circumstances.** When connected with 120 volts, the appliance must be electrically grounded in accordance with local codes, current version of the Canadian Electrical Code CSA C22.1 (in Canada) or in the absence of local codes, with the National Electrical Code ANSI/NFPA 70.

WARNING:
Electrical Grounding Instructions

This appliance is equipped with a three pronged (grounding) plug for your protection against shock hazard and should be plugged directly into a properly grounded three-prong receptacle. Do not cut or remove the grounding prong from this plug.

Minimum Fireplace Opening

The minimum fireplace opening for the L234 gas fireplace insert is shown in the following diagrams:

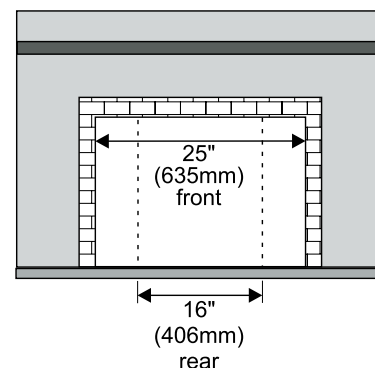
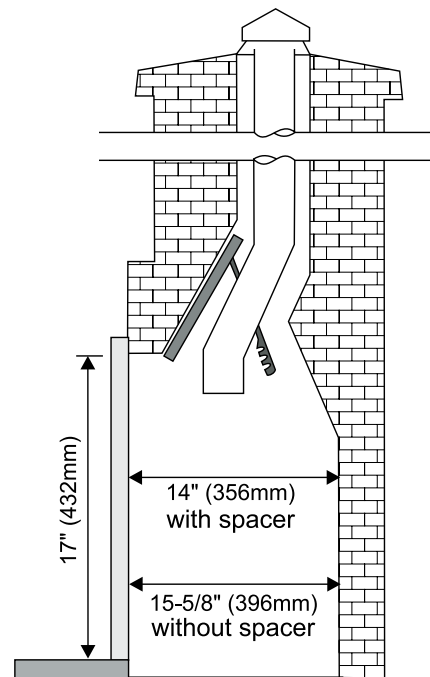

installation

Minimum Clearances To Combustibles

Unless otherwise stated the clearances listed below are Minimum distances to combustible materials. **Please Note: A major cause of chimney related fires is due to a failure to maintain required clearances (air space) to combustible materials. It is of the greatest importance that this insert and vent system be installed only in accordance with these instructions.**

Side Walls **A** 8" (203 mm)*/**

Ceiling **B** 56" (1422 mm)

Min. Mantel Height **C** 21" (533 mm) see Diagram 1

Max. Mantel Depth **D** 12" (305 mm) see Diagram 1

Alcove Width **E** 60" (1524 mm)

Alcove Depth **F** 36" (914 mm)

****Hearth Height- Noncombustible** **G** 1-1/2" (38 mm) Minimum

Hearth Width **H** 28" (686 mm)

Hearth Depth **I** 12" (305 mm)

* Alcove side wall must have a minimum of 8" clearance.
 **Note: A 1-1/2" high non-combustible hearth is required if unit is not raised off the ground a minimum of 4".

***Measured from edge of glass frame.

(J) Glass Frame Width (Reference Only): 25" (635mm)

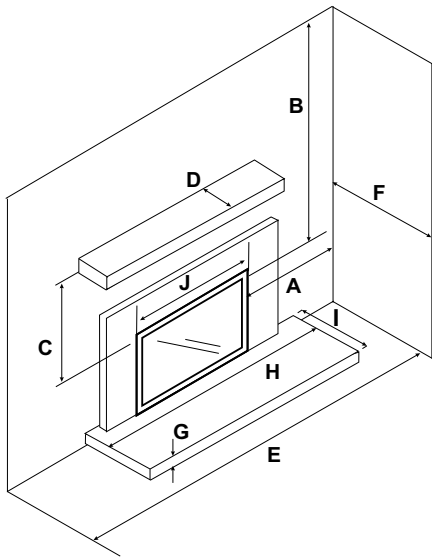

INSTALLATION WITH NON-COMBUSTIBLE HEARTH IN FRONT

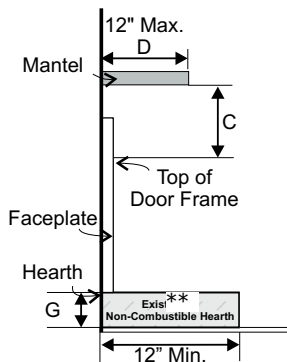

Combustible Mantel Clearances

Because of the extreme heat this fireplace emits, the mantel clearances are critical. Combustible mantel clearances from top of door frame are shown in the diagram below. Mantel may be installed anywhere in the shaded area or higher.

Note: A non-combustible mantel may be installed at a lower height. The non-combustible mantel when installed at a lower overall height may not be lower than 6 inches from the top of the fireplace opening.

Note: Ensure the paint that is used on the mantel and the facing is "heat resistant" or the paint may discolour.

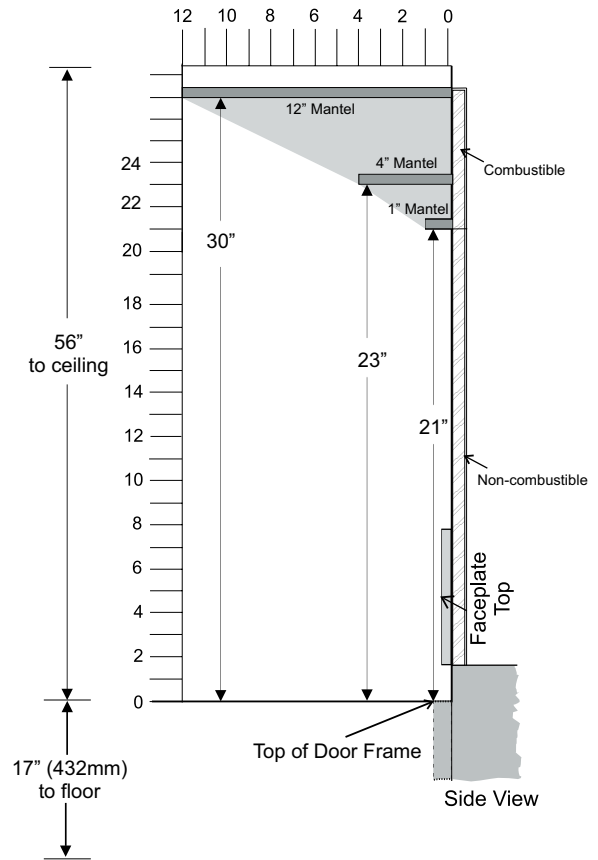
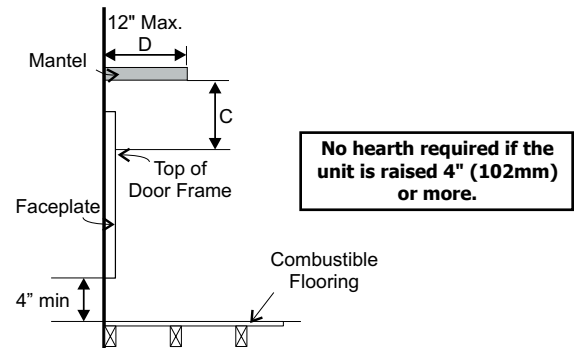

Diagram 1

INSTALLATION WITH COMBUSTIBLE FLOORING IN FRONT



Venting

THE APPLIANCE MUST NOT BE CONNECTED TO A CHIMNEY FLUE SERVING A SEPARATE SOLID FUEL BURNING APPLIANCE.

This appliance is designed to be attached to two 3" (76 mm) co-linear aluminium flex running the full length of the chimney. The flue length must be a minimum length of 8' (2.43 m) and a maximum of 35' (10.67 m). Periodically check that the vent is unrestricted.

Masonry chimneys may take various contours which the flexible liner will accommodate. However, **keep the flexible liner as straight as possible**, avoid unnecessary bending.

IMPORTANT: Use only the listed termination caps and flex liner noted on this page. This appliance was tested/certified as a complete system with the noted termination caps and flex liner. Use of termination caps or flex liner not listed in this manual will void the warranty and certification of this appliance. It is also important not to enclose the termination cap inside of a masonry chimney rain cap, or similar. The termination must be exposed on all four sides and above to exhaust, and to draw air into the firebox.

INSTALLATION WITH 3" (76 mm) & 3" (76 mm) LINERS

Part #	Description
948-305	3" (76 mm) Flex - 35 ft. (10,67 m) (intake & exhaust)
946-529	Regency Co-linear DV Vertical Termination Cap & Flashing

Vent Run	Vent Restrictor Position	Burner Aeration Setting
8' to 20'	1" (25 mm)	3/16" (5 mm)
20' to 35'	3/4" (19 mm)	3/16" (5 mm)

NOTE: See instructions in the "Vent Restrictor Position" section on positioning of the vent restrictor.

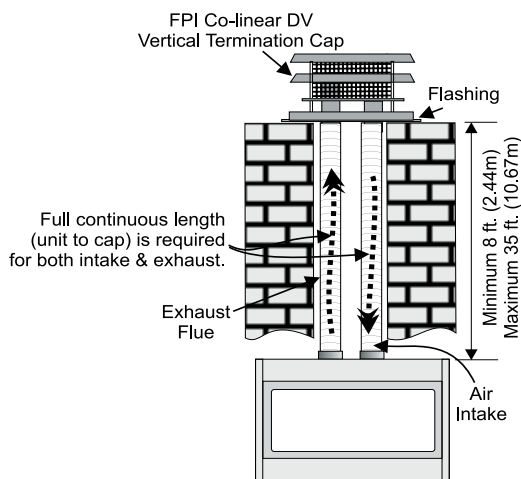

Alternative Approved Venting Components*

- 46DVA-VC Vertical Termination Cap
- 46DVA-VCH High Wind Cap
- 46DVA-GK 3" (76 mm) Co-linear Adaptor with flashing

In areas of consistently high winds, we recommend using the Simpson Dura-Vent System 46DVA-GK adapter and 46DVA-VCH high-wind cap. The Air Intake pipe must be attached to the inlet air collar of the termination cap.

***NOTE:** Simpson DuraVent can only be used with 3" (76 mm) liners.

The L234 is also approved for use with a 2" liner for air intake and a 3" liner for exhaust. This would be suitable for a Class A wood burning chimney with a minimum 6" round flue.

The chimney must be lined with one 2" diameter liner for intake and one 3" diameter liner for exhaust. The minimum vent length is 8' and maximum is 35'.

INSTALLATION WITH 3" & 2" LINERS

Part #	Description
948-305	3" (76 mm) Flex - 35 ft. (10,67 m) (exhaust)
948-316	2" (51 mm) Flex - 35 ft. (10,67 m) (intake)
946-582	Regency Co-linear DV Vertical Termination Cap, Flashing & 2" (51 mm) Collar

Vent Run	Vent Restrictor Position	Burner Aeration Setting
8' to 20'	1" (25 mm)	3/16" (5 mm)
20' to 35'	1" (25 mm)	1/8" (3 mm)

NOTE: See instructions in the "Vent Restrictor Position" section on positioning of the vent restrictor.

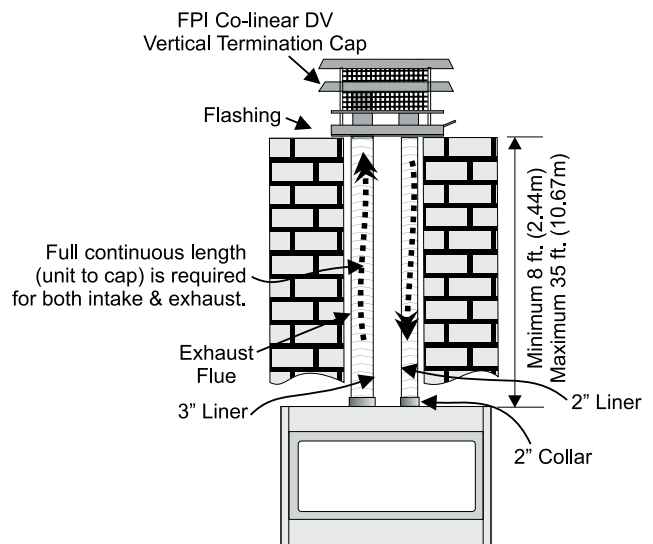

installation

Converting from 3" (76 mm) & 3" (76 mm) Venting to 3" (76 mm) & 2" (51 mm)

- 1) Remove the top plate from the unit by undoing the screw at the front of the firebox and slide out towards the back of the unit.

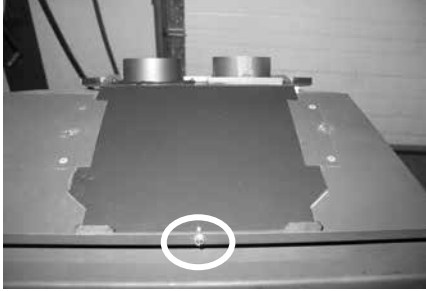

- 2) Remove the 3" (76 mm) collar from the top plate by undoing the 4 screws.

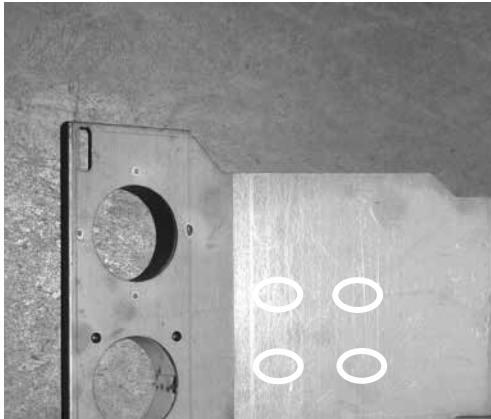

Underside of Top Plate

NOTE: The screws are secured from the underside of the top plate.

- 3) Secure the 2" (51 mm) collar to the top plate using 4 screws in place of the 3" (76 mm) collar.
- 4) Re-install the top plate to the unit.



Top Plate with 2" Collar shown on Unit

Vent Restrictor Position

The Vent Restrictor plate is located on the inside top of the firebox.

To change the vent restrictor position, refer to the instructions below;

- 1) Remove the glass door.
- 2) Remove brick panels if installed.
- 3) Remove the 4 screws that hold the vent restrictor plate in place.



- 4) Adjust the vent restrictor plate to the required vent restrictor position.



Factory Set at 1"

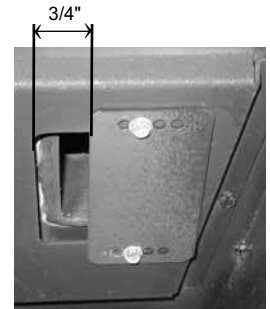

Adjusted to 3/4"

- 5) Once the vent restrictor plate is in the required position, secure using the 4 screws removed from step 3.
- 6) Re-install brick panels if removed.
- 7) Re-install glass door.

Flue Liner Installation

- 1) Cut the flex liner as required.
- 2) **Mark the end of one liner with an "E" to indicate Exhaust.**
- 3) Connect the other end of the above liner to the exhaust side of the termination cap, seal connection with high temperature silicone. Secure with gear clamp or screws.
- 4) Connect the 2nd liner to the inlet side of the cap, seal connection with high temperature silicone. Secure with gear clamp or screws.
- 5) Install flashing.
- 6) Insert both liners into chimney, passing through the damper opening.
- 7) Install termination cap.
- 8) Connect the **marked end** of the liner to the exhaust collar of the vent connector plate marked with an "E", seal connection with high temperature silicone. Secure with gear clamp or screws.

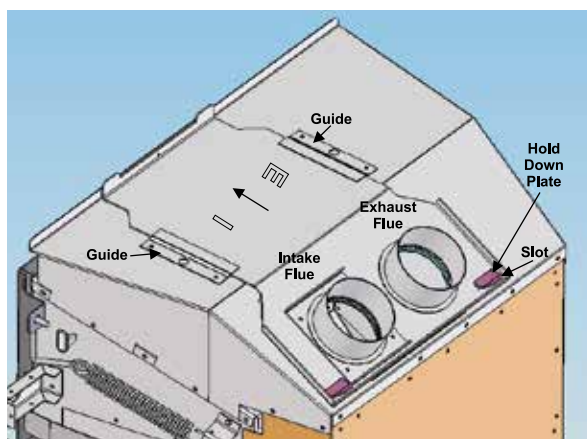

- 9) Connect the 2nd liner to the intake collar, seal connection with high temperature silicone. Secure with gear clamp or screws.
- 10) Align vent connector plate with guides on unit.
- 11) Slide unit into masonry opening, while ensuring that the slot at the rear of the connector plate mates up with the hold down plate on the unit.
- 12) Secure with screw.

NOTES:

- 1) Final gas connection should be made after unit is in place to avoid damage to the liner when pushing the unit into position.
- 2) Mill-pac may be used instead of high temperature silicone and screws may be used instead of gear clamps at connections of liner to inlet and vent collars.

Gas Connection

GAS CONNECTION WARNING:
Only persons licensed to work with gas piping may make the necessary gas connections to this appliance.

- 1) When the appliance is to be installed into either an existing masonry chimney system or factory built fireplace, thoroughly clean the chimney before installation.
- 2) A 3/8" NPT gas supply pipe must be brought near the inlet hole. The valve inlet is on the right side of the unit.

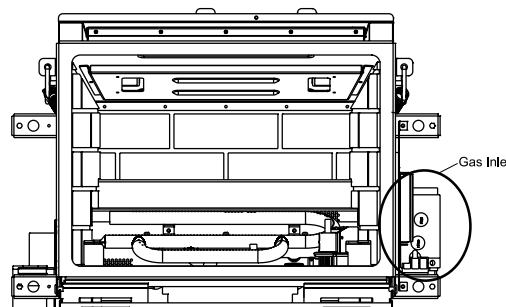

- 3) Locate the center point where the vent will pass through the chimney above the appliance. Move the appliance into the exact location where it is to be installed. Ensure that the Insert is level.

NOTE: This unit is equipped with a heat sensor thermodisc which will prevent the blower from operating until the unit reaches the correct temperature.

installation

Gas Insert Aeration Adjustment

The burner aeration is factory set but may need adjusting due to either the local gas supply or altitude. Open the air shutter for a blue flame or close for a more yellow flame. To access burner aeration—see Steps below.

CAUTION: Carbon will be produced if the air shutter is closed too much.

Minimum Air Shutter Openings		
	Vent Run	Burner Aeration Setting
3" (76 mm) x 3" (76 mm)	8' to 20' (2.43 m to 6.1 m)	NG: 3/16" (5 mm) LP: 3/16" (5 mm)
	20' to 35' (6.1 m to 10.67 m)	NG: 3/16" (5 mm) LP: 3/16" (5 mm)
3" (76 mm) x 2" (51 mm)	8' to 20' (2.43 m to 6.1 m)	NG: 3/16" (5 mm) LP: 3/16" (5 mm)
	20' to 35' (6.1 m to 10.67 m)	NG: 1/8" (3 mm) LP: 1/8" (3 mm)

Note: Any damage due to carboning resulting from improperly setting the aeration controls is NOT covered under warranty.

Note: Aeration Adjustment should only be performed by an authorized Regency Installer at the time of installation or service.

1. Remove the outer faceplate.
2. Remove the safety screen.
3. Remove the glass door.

a) Pull the spring hook on the left that holds the door in place. Place the hook into the opening towards the outside of the bracket. Repeat on right side.

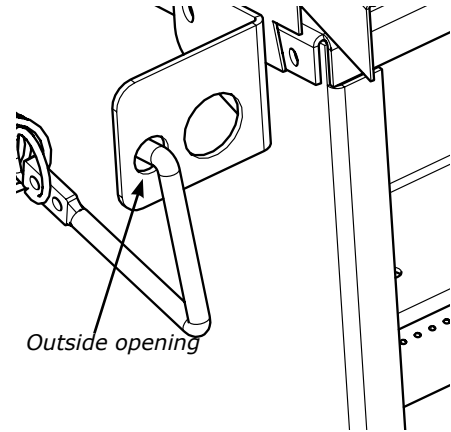
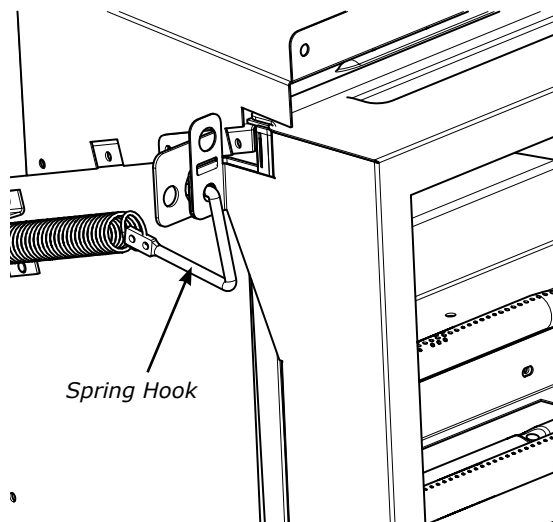

b) Swing the door out 45 degrees and lift up and out.



4. Remove the logs.
5. Remove brick panels, if installed.
6. Remove the burner by undoing the 3 screws.

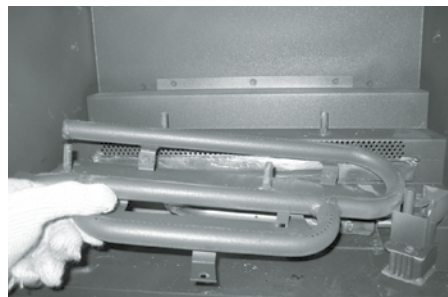
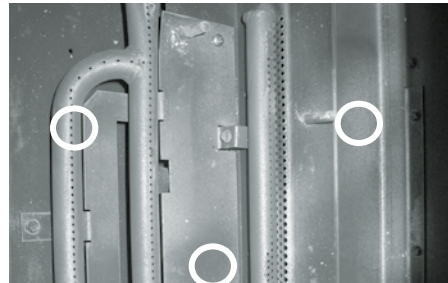

Burner Removed

7. Make necessary aeration adjustment - reverse Steps 6-1.

Gas Pipe Pressure Testing

The appliance must be isolated from the gas supply piping system by closing its individual manual shut-off valve during any pressure testing of the gas supply piping system at test pressures equal to or less than 1/2 psig. (3.45 kPa). Disconnect piping from valve at pressures over 1/2 psig.

The manifold pressure is controlled by a regulator built into the gas control, and should be checked at the pressure test point.

NOTE: To properly check gas pressure, both inlet and manifold pressures should be checked using the valve pressure ports on the valve.

- 1) Make sure the valve is in the "OFF" position.
- 2) Loosen the "IN" and/or "OUT" pressure tap(s), turning counterclockwise with a 1/8" wide flat screwdriver.
- 3) Attach manometer to "IN" and/or "OUT" pressure tap(s) using a 5/16" ID hose.
- 4) Light the pilot and turn the valve to "ON" position.
- 5) The pressure check should be carried out with the unit burning and the setting should be within the limits specified on the safety label.
- 6) When finished reading manometer, turn off the gas valve, disconnect the hose and tighten the screw (clockwise) with a 1/8" flat screwdriver.
Note: Screw should be snug, but do not over tighten.

SIT 829 Valve Description

- 1) Gas on/off knob
- 2) Electronically Operated Hi/Lo
- 3) Pilot Adjustment
- 4) Thermocouple Connection - *option*
- 5) Outlet Pressure Tap
- 6) Inlet Pressure Tap
- 7) Pilot Outlet
- 8) Main Gas Outlet
- 9) Alternative TC Connection Point

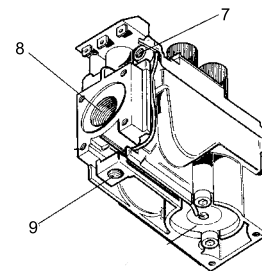
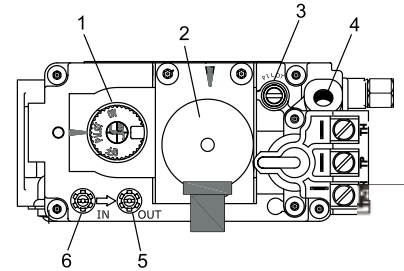

LP Conversion Instructions

THIS CONVERSION MUST BE DONE BY A QUALIFIED GAS FITTER, IF IN DOUBT DO NOT DO THIS CONVERSION!!

LP Conversion Kit Contains:

Qty.	Part #	Description
1	910-037	LP Pilot Orifice
1	904-163	Orifice #54
1	904-529	5/32" Allen Key
1	910-582	Stepper Motor
1	918-590	LP Conversion Decal
1	908-528	Red Propane Label
1	919-465	Instruction Sheet

1. Shut off gas and electrical supply to the unit.
2. Remove the faceplate.
3. Remove the safety screen and glass door - see manual for detailed instructions.
4. Remove the logs if installed.
5. Remove the brick panels if installed.
6. Remove the burner by undoing the 3 screws.

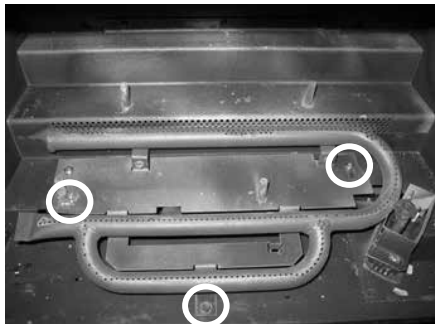

Burner Removed



7. Remove the burner tray by undoing the 4 screws.

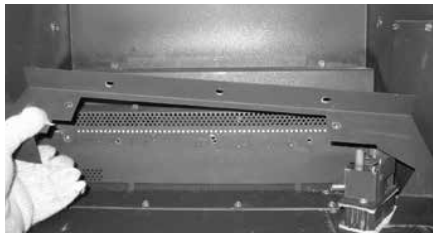
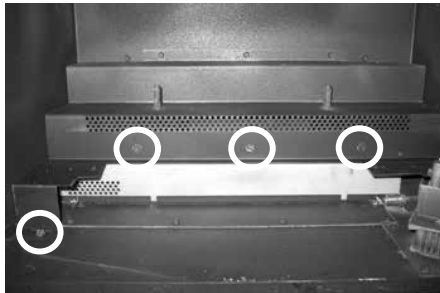

Burner Tray Removed

8. Remove burner orifice with a 1/2" wrench and discard.

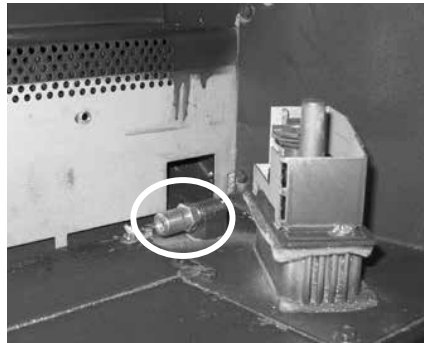

9. Install the new LP burner orifice stamped #54 and tighten.

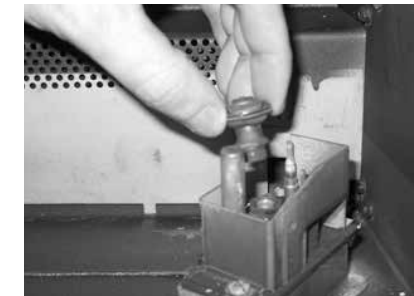

10. Pull off the pilot cap to expose the pilot orifice.

11. Unscrew the pilot orifice with the supplied allen key and replace it with the LP pilot orifice in the kit and re-install the pilot cap.



12. Remove the pilot/on/off extension knob by pulling the knob towards you. Remove NG stepper motor by removing 3 screws in locations shown below—replace with LP stepper motor, secure in place with 3 screws.



Remove NG Stepper motor and replace with LP Stepper motor

13. Reinstall the pilot/on/off extension knob removed from step 12. Check for gas leaks with a proper soapy solution or leak detector.

14. Check inlet and outlet pressures. Refer to "Gas Pipe Pressure Testing" section of the manual.

15. Attach the label "This unit has been converted to LP" near or on top of the serial # decal.

16. Replace yellow "NG" label with red "LP" label.

17. Reverse Steps 8 - 1.

NOTE: before re-installing burner, check the LP aeration settings.

18. Check operation of flame control.

19. Check for proper flame appearance and glow on logs.

Optional Brick Panel Installation

- 1) Carefully remove the brick panels from the box and unwrap them.
- 2) Insert the back brick panel by carefully placing it against the back wall of the firebox and rest it on the rear log tray.
- 3) Slide the right side brick panel into position and secure in place using the brick clip. Repeat for left side.

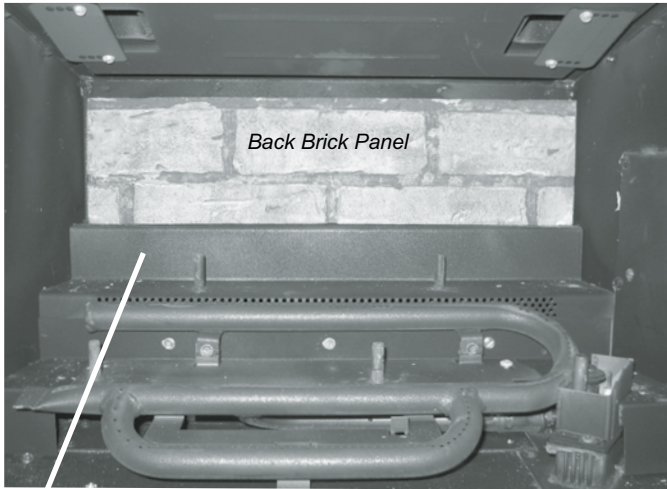

Rear Log Tray

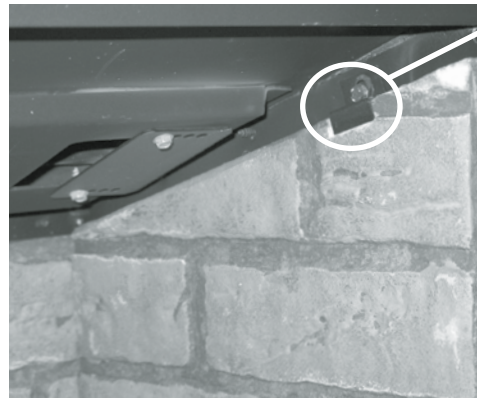

Brick Clip

Right Side Brick Panel

IMPORTANT

YOUR BRICK PANELS ARE
MANUFACTURED FROM A SPECIAL HEAT
REFLECTIVE CERAMIC MATERIAL
HANDLE WITH CARE
(DO NOT FORCE INTO POSITION)

Completed Brick Panel Installation

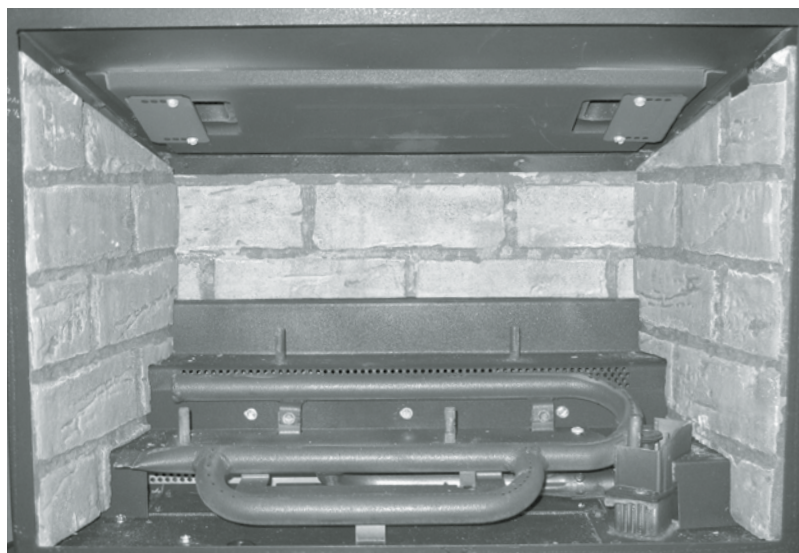

installation

Safety Screen Install

1. Slide the folded tab on the screen assembly over the tab on the glass door (left and right sides).

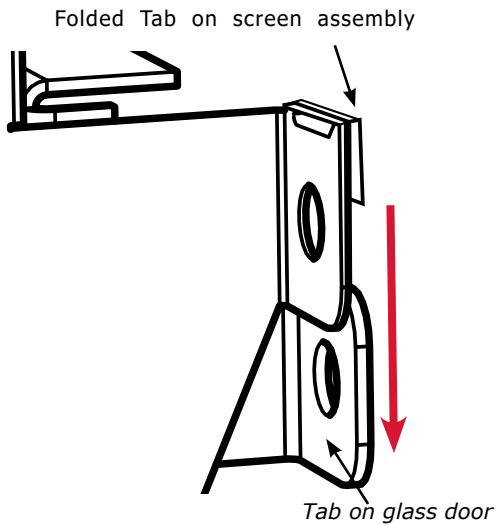
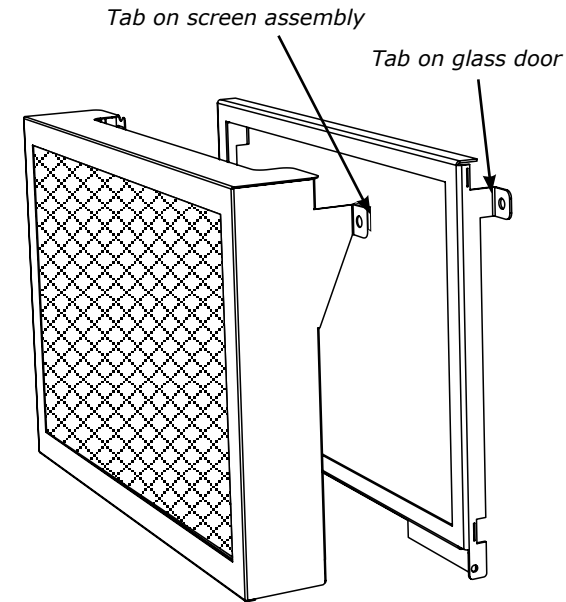

2. Install screen assembly and glass door together and secure with spring hooks on left and right side. To remove see "Glass Door Removal" instructions.

Spring Hook

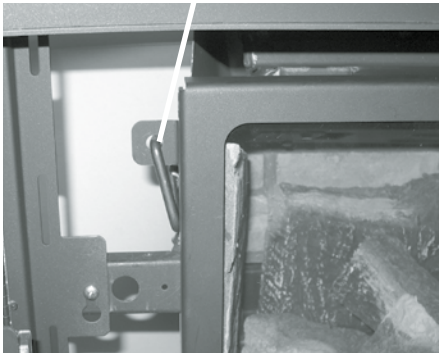

Glass Door Removal/Install

1. Remove the glass door.

- a) Pull the spring hook on the left that holds the door in place. Place the hook into the opening towards the outside of the bracket. Repeat on right side.

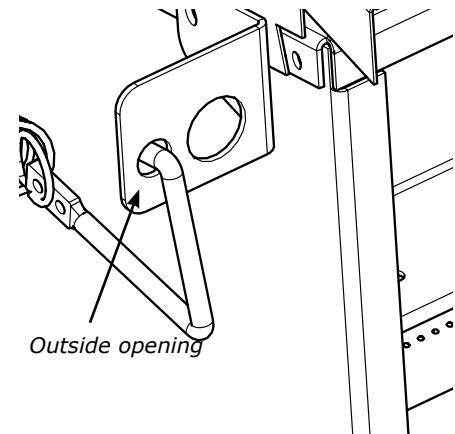
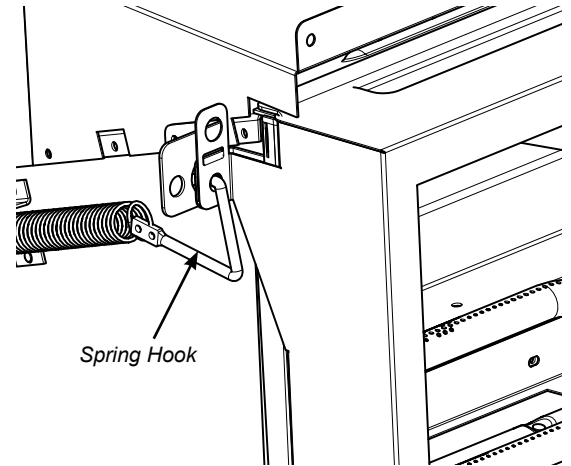

- b) Swing the door out 45 degrees and lift up and out.



2. To reinstall—reverse steps.

Log Set Installation

Read the instructions below carefully and refer to the images. Dangerous operating conditions may occur if the logs are not positioned in their correct locations. If the logs are broken do not use the unit until they are replaced. Broken logs can interfere with the pilot operation.

Log kit (Part # 536-930) contains the following pieces:

- a) 2-711 Rear Log
- b) 2-712 Center Log
- c) 2-713 Left Log
- d) 2-714 Front Log
- e) 2-715 Top Left Log
- f) 2-716 Top Right Log
- g) 902-156 Embers (supplied with packaged manual)
- h) 946-669 Platinum Embers (supplied with packaged manual)
- i) 946-708 Embaglow Embers (supplied with packaged manual)

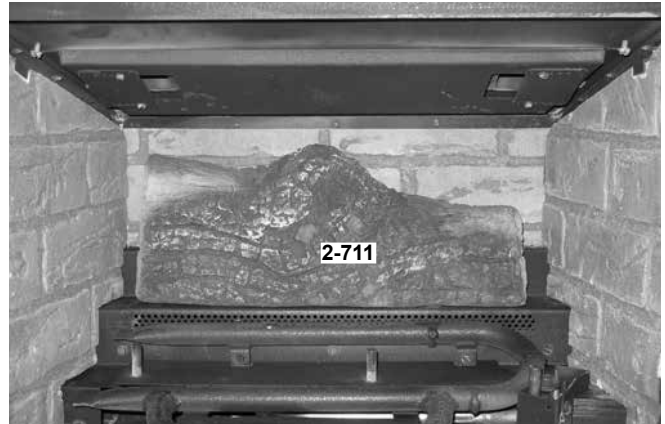

3) Place log 2-714 on the base of the firebox in front of the burner.

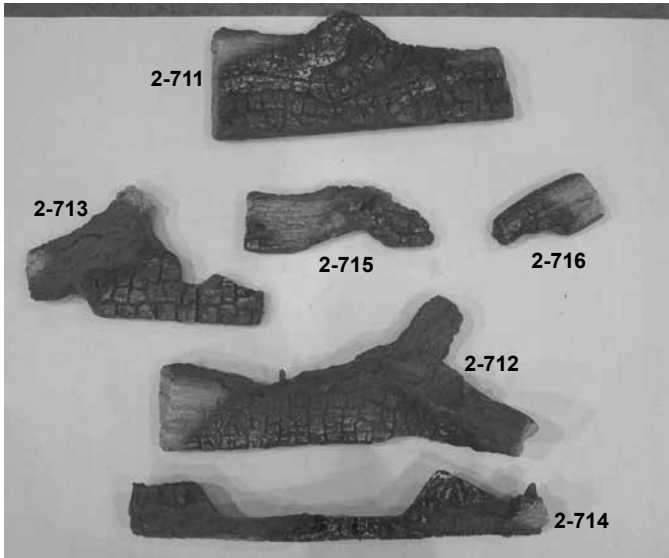

4) Fit log 2-712 into the pins on the middle of the burner.

- 1) Carefully remove the logs from the box and unwrap them. The logs are fragile, handle with care - **do not force into position**.
- 2) Fit log 2-711 into the pins on the rear log tray.

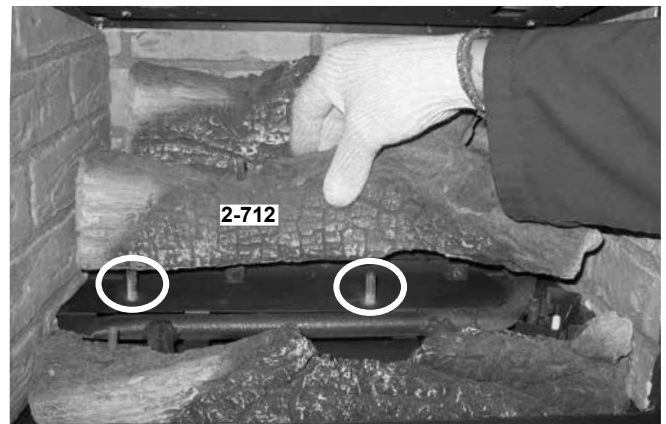
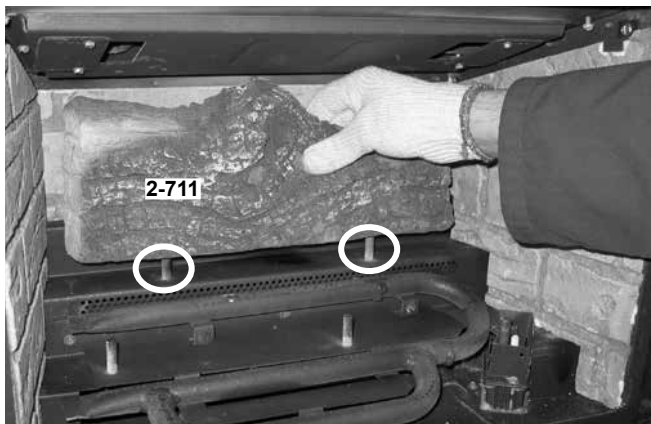

installation



- 5) Fit the left side of log 2-713 into the pin on log 2-714 and rest the right side of the log on the burner plate pushing it against the tab.

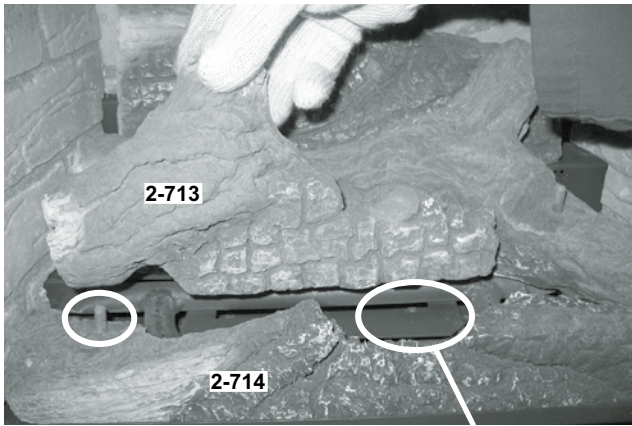

- 6) Place log 2-715 into the pin on log 2-712 and rest the right end of the log on the notch in log 2-713.

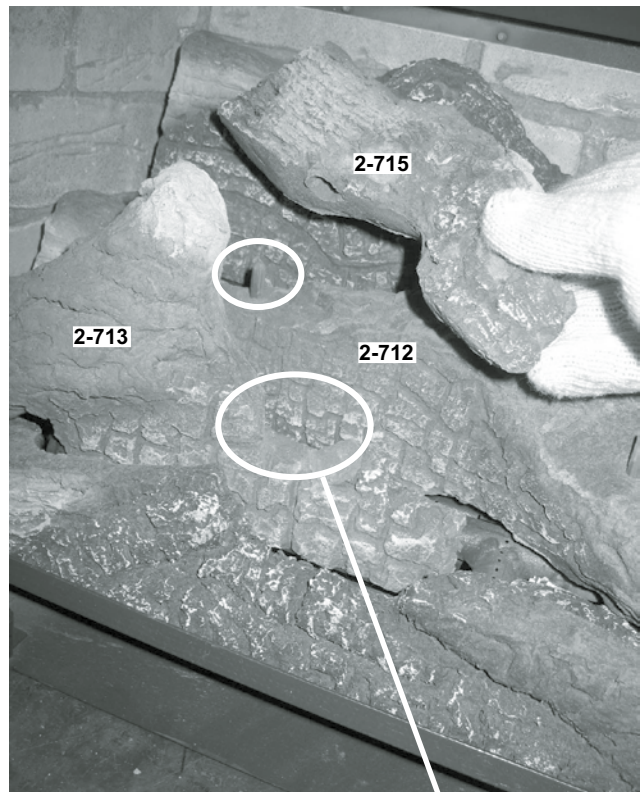

- 7) Place embers on the right side of the burner as shown.



Right side of Burner

Also place a few embers along the burner tube next to log 2-713.

Separate platinum embers and place on and around the embers. Avoid stacking platinum embers. Separate the Embaglow embers and place over the platinum embers. Both platinum embers and Embaglow embers can be directly over the burner ports to create a glow. Separate the Embaglow embers and place over the platinum embers. Both platinum embers and Embaglow embers can be directly over the burner ports to create a glow.

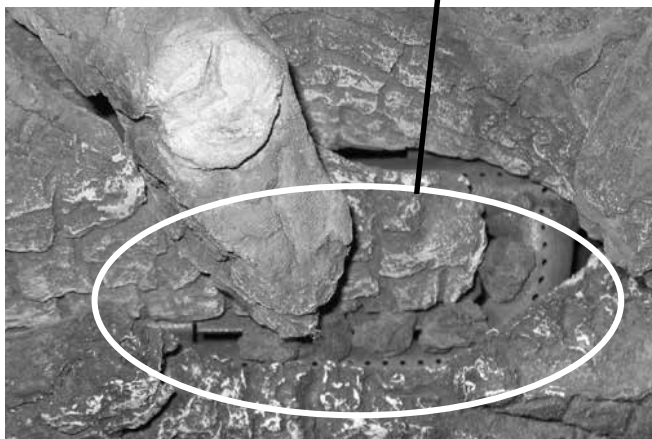

- 8) Fit log 2-716 into the pin on log 2-712.



Completed Log Set Installation

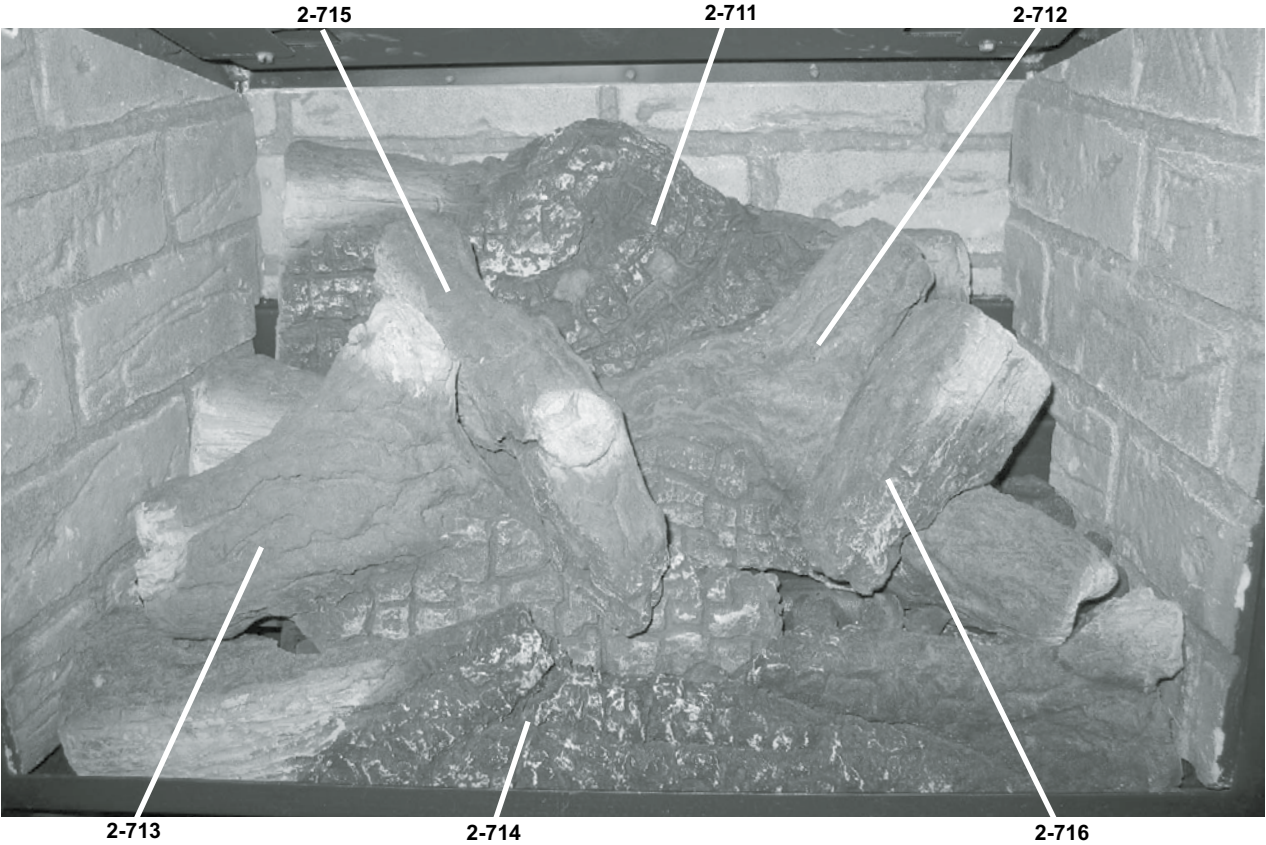

Low Profile Faceplate Installation

- * If no spacer is required, proceed to Step 2.
If an optional spacer is required, secure the faceplate backing to the spacer with two screws in the locations shown below. Attach the faceplate backing and spacer to the unit together, as shown in Step 2.

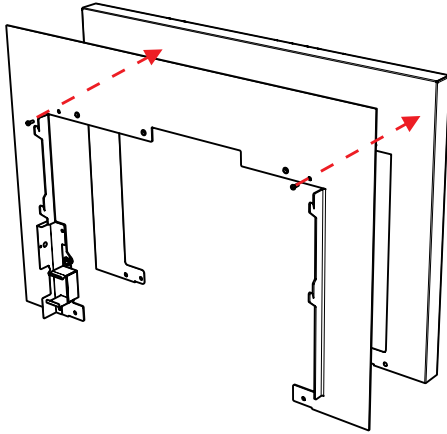

- Position the faceplate backer (and spacer, if required) behind the flange on the unit and secure with five screws in the location shown below.

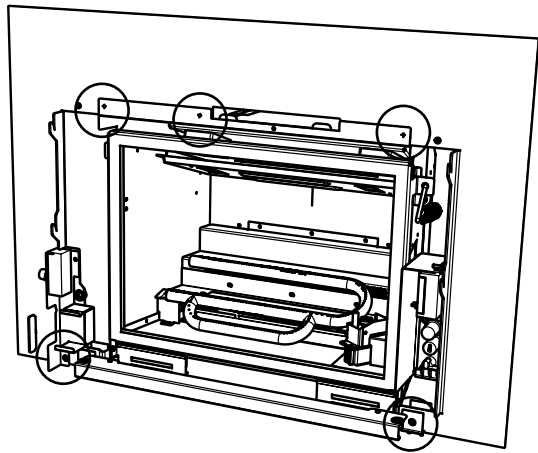

- Install the receiver into the bracket using two flat head screws (1). Install the bracket using two black pan head screws (2). The receiver is already wired to the appliance. Tuck all wires into the bracket (see wiring diagram for details).

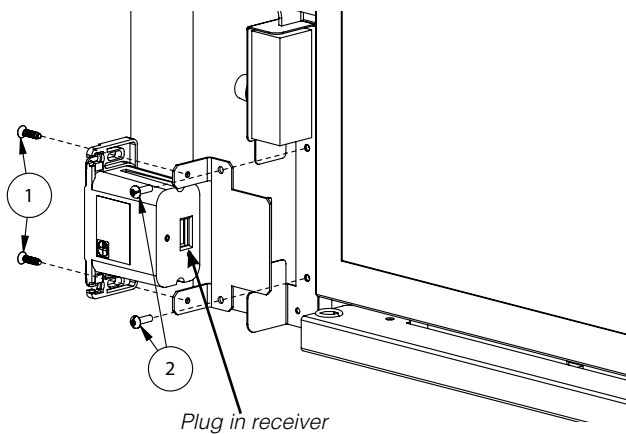

- Install the safety screen over the glass door by opening the door and sliding the tab on the safety screen over the tab on the glass door as shown below, then install the door and screen together. For further details, see the manual.

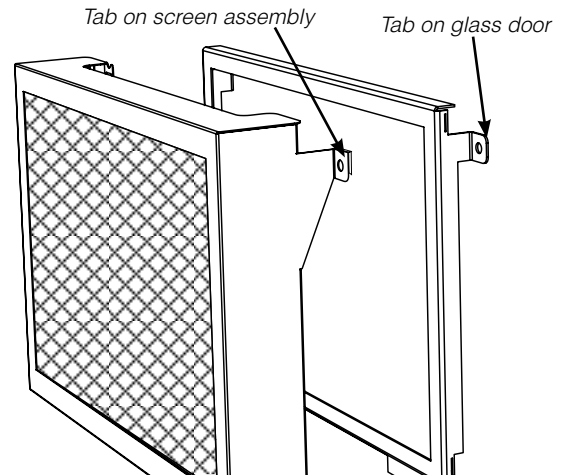

- Install the receiver into the bracket located on the left side of the backing plate. The receiver is pre-wired to the appliance. Tuck all wires into bracket. See wiring diagram for details.

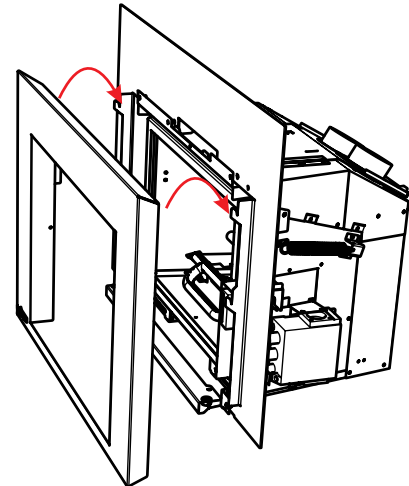

- Install the outer faceplate by hooking on to the brackets on the faceplate backing.

- To remove—reverse steps.

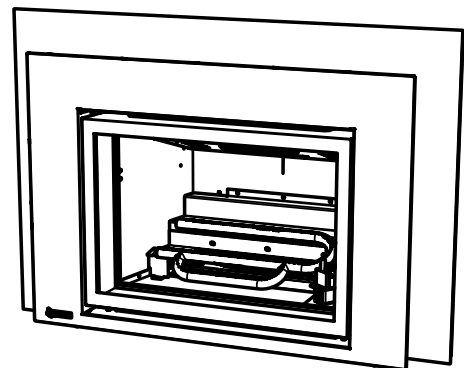

installation

Hearth Trim Installation

Customize Hearth Trim:

- a) The Hearth Trim can be adjusted to custom fit an installation by pulling apart the top piece from the bottom piece.
- b) Cut the top of the bottom piece of the hearth trim to the appropriate height using a metal cutting blade.
NOTE: The tab bends at the back of the top piece of the hearth trim should be used as the measuring point to the hearth to measure the height required.
- c) Reattach the top piece of the hearth trim to the cut bottom piece by fitting in place.

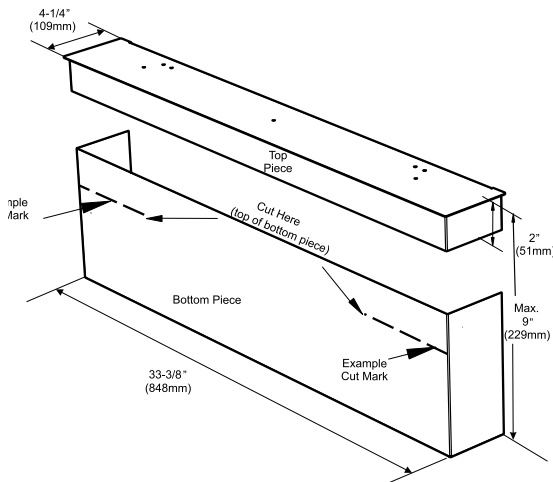

Hearth Trim Installation:

- 1) Align the screw holes on the hearth trim brackets with the screw holes on the lower legs of the faceplate backing. Secure in place using 1 screw through hearth trim bracket and lower leg of faceplate backing on each side as shown in Diagram 1.

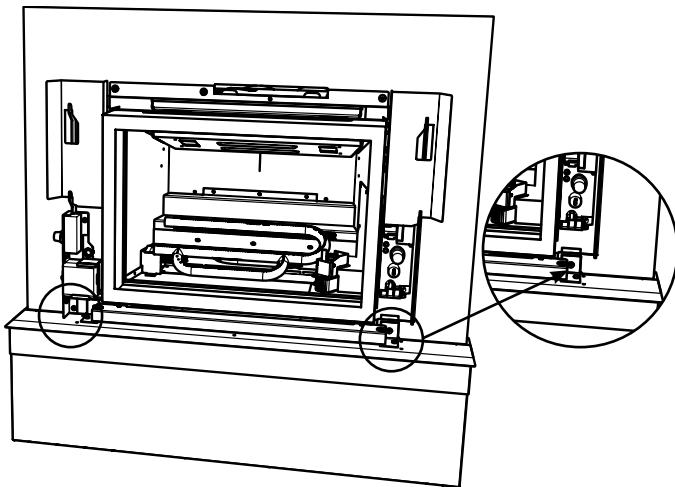

Diagram 1

- 2) Attach the supplied brackets to the top of the hearth trim with 2 screws. Note: orientation of brackets is different when using spacer.

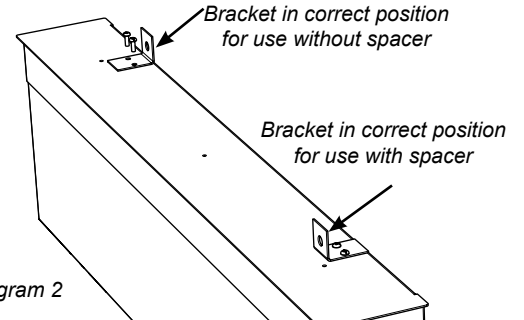
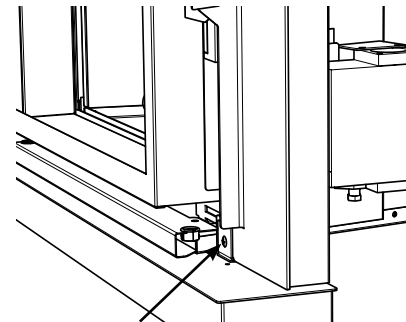

Diagram 2

- 3) Install the hearth trim through the lower legs of the faceplate backer and spacer together.



Install hearth trim with faceplate backer and spacer together - same location as in Step 1

Diagram 3

- 4) Install outer faceplate.

Completed Hearth Trim Installation:

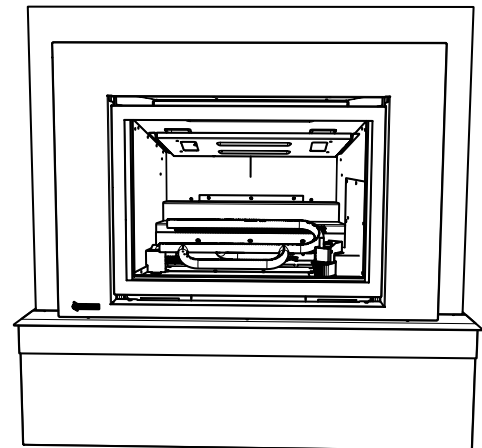

Diagram 4

Wiring Diagrams

This heater does not require a 120V A.C. supply for operation. However, a 120V A.C. power supply is needed for the fan/blower operation.

Caution: Ensure that the wires do not touch any hot surfaces and are away from sharp edges.

CAUTION: Label all wires prior to disconnection when servicing controls. Wiring errors can cause improper and dangerous operation.

WARNING: Electrical Grounding Instructions
 This appliance is equipped with a three pronged (grounding) plug for your protection against shock hazard and should be plugged directly into a properly grounded three-prong receptacle. Do not cut or remove the grounding prong from this plug.

Note: Batteries are required in both remote receiver (4 x AA Batteries) & remote hand held (3 x AAA batteries) in order to operate appliance using the remote control.

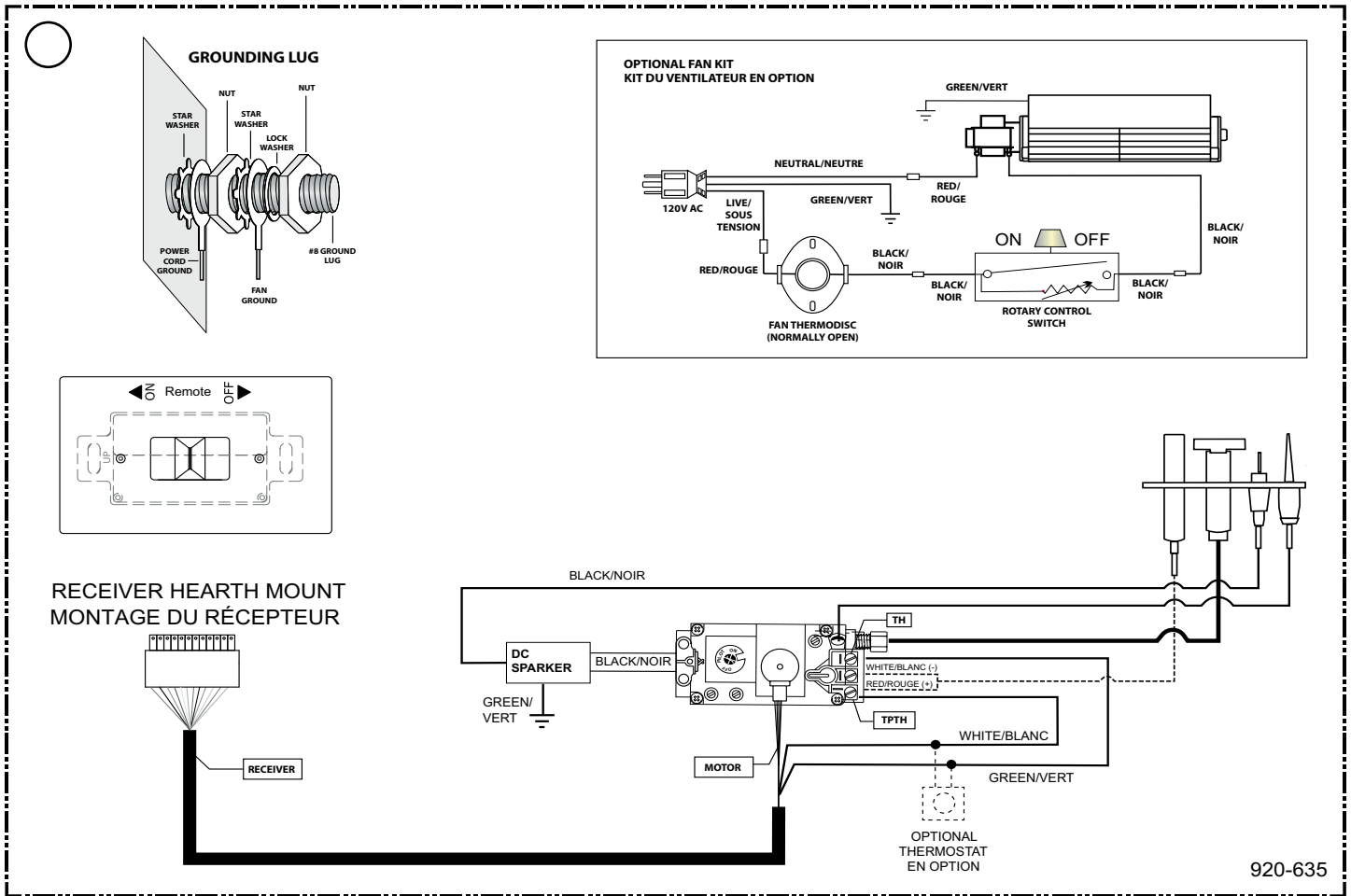

920-635

IMPORTANT: Thermopile leads must be attached to the gas valve as follows:
 Red lead (Positive) to the TP/TH terminal
 White lead (Negative) to the TP terminal

installation

Optional Wall Thermostat

A wall thermostat may be installed if desired, follow the wiring diagram below. Note: the wires are connected to the "TH" on the gas valve. Use the table below to determine the maximum wire length. Regency offers an optional programmable thermostat but any 250-750 millivolt rated non-anticipator type thermostat that is CSA, ULC or UL approved may be used.

It is recommended that the thermostat be installed on an interior wall.

CAUTION
Do not connect the millivolt wall thermostat wires to the 120V wires.

Thermostat Wire Table	
Recommended Maximum Lead Length (Two-Wire) When Using Wall Thermostat (CP-2 System)	
Wire Size	Max. Length
14 GA.	50 Ft.
16 GA.	32 Ft.
18 GA.	20 Ft.
20 GA.	12 Ft.
22 GA.	9 Ft.

Final Check

Before leaving this unit with the customer, the installer must ensure that the appliance is firing correctly. This includes:

- 1) Clocking the appliance to ensure the correct firing rate (noted on label) at 15 minutes.
- 2) If required, adjusting the primary air to ensure that the flame does not carbon. First allow the unit to burn for 15 min. to stabilize.
- 3) Check for proper draft.

CAUTION
Any alteration to the product that causes sooting or carboning that results in damage to the exterior fascia is not the responsibility of the manufacturer.

DC Spark Igniter Battery Installation

Install the supplied battery into the DC Sparker Box by opening the battery compartment.

NOTE: The battery in the DC Sparker Box will need to be replaced annually.



operating instructions

First Fire

The first fire in your insert is part of the paint curing process. To ensure that the paint is properly cured, it is recommended that you burn your fireplace for at least four (4) hours the first time you use it with the fan on. When first operated, the unit will release an odour caused by the curing of the paint, the burning off of any oils remaining from manufacturing. Smoke detectors in the house may go off at this time. Open a few windows to ventilate the room for a couple of hours.

The glass panel may require cleaning after the unit has cooled down.

DO NOT ATTEMPT TO CLEAN THE GLASS WHILE IT IS HOT.

Note: When the glass is cold and the appliance is lit, it may cause condensation and fog the glass. This condensation is normal and will disappear in a few minutes as the glass heats up.

DO NOT BURN THE APPLIANCE WITHOUT THE GLASS FRONT IN PLACE.

During the first few fires, a white film may develop on the glass front as part of the curing process. The glass should be cleaned or the film will bake on and become very difficult to remove. Use a non-abrasive cleaner and NEVER clean the glass while it is hot.

Operating Instructions

- 1) Read and understand these instructions before operating this appliance.
- 2) Check to see that all wiring is correct and enclosed to prevent possible shock.
- 3) Check to ensure there are no gas leaks.
- 4) Make sure the glass in the door frame is properly positioned. Never operate the appliance with the glass removed.
- 5) Verify that the venting and cap are unobstructed.
- 6) Ensure that the brick panels, if used, are installed.
- 7) Verify log placement. If the pilot cannot be seen when lighting the unit, the logs have been incorrectly positioned.
- 8) The unit should never be turned off, and on again without a minimum of a 60 second wait.

- 9) Hook up remote receiver to wire marked 'receiver' which will be located on the bottom of the appliance. This remote control requires coding. See remote control instructions for details.

NOTE: This appliance will operate during power outages. Only the fan will not operate until power is restored. If the remote batteries in both the handheld transmitter or receiver lose power, the appliance can still be operated by sliding the switch on the receiver switch from "Remote" to "ON". To turn on the appliance off slide the receiver switch from "ON" to "Remote" or "OFF".

IMPORTANT: The remote control system supplied with this appliance has several options for starting/operating the appliance, please read the remote control operating instructions (packed with remote control) to understand how to operate this remote system. Option to download remote functions video with QR code below.



Proflame video

Lighting Procedure

IMPORTANT
Prior to igniting or re igniting the pilot, remove the glass door.

Important: If the pilot does not hold, turn pilot knob to "OFF" position. Wait 5 minutes to clear gas. If you smell gas - STOP! Follow the safety information above. If you don't smell gas, repeat Steps 1-6.

1. Push in gas control knob slightly and turn to "PILOT" position.
2. Push in control knob all the way and hold in until the pilot lights up. Continue to hold the control knob in until a faint buzzer sound can be heard for 4 seconds informing the operator that the knob can now be released. Release knob.
3. Push in gas control knob slightly and turn to "ON" position.
4. Ensure the receiver is in the remote position.

Set Switch to Remote



Diagram 1

5. Press and release the ON/OFF button on the remote handheld transmitter. An audible beep should be heard from the receiver.



Diagram 2

Remote shown in Manual Mode on Hi

Note: May not be exactly as shown as hand-held may be silver or black.

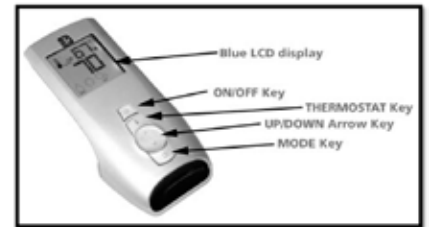

6. The unit will turn on.

Shutdown Procedure

1. Press "OFF" on the remote or slide receiver switch from remote to "OFF".
2. Turn the gas control knob to the "OFF" position to turn off the pilot.

Pilot may be shut off during prolonged non use periods to conserve fuel.

operating instructions

Normal Operating Sounds Of Gas Appliances

It is possible that you will hear some sounds from your gas appliance. This is perfectly normal due to the fact that there are various gauges and types of steel used within your appliance. Listed below are some examples. All are **normal operating sounds** and should not be considered as defects in your appliance.

Blower:

Regency gas appliances use high tech blowers to push heated air farther into the room. It is not unusual for the fan to make a "whirring" sound when ON. This sound will increase or decrease in volume depending on the speed setting of your fan speed control.

Burner Tray:

The burner tray is positioned directly under the burner tube(s) and logs and is made of a different gauge material from the rest of the firebox and body. Therefore, the varying thicknesses of steel will expand and contract at slightly different rates which can cause "ticking" and "cracking" sounds. You should also be aware that as there are temperature changes within the unit. These sounds will likely re-occur. Again, this is normal for steel fireboxes.

Blower Thermodisc:

When thermally activated switch turns ON, it will create a small "clicking" sound. This is the contact switch closing.

Pilot Flame:

While the pilot flame is on it will make a slight "whisper" sound.

Gas Control Valve:

As the gas control valve turns ON and OFF, a dull clicking sound may be heard. This is normal operation of a gas regulator or valve.

Unit Body and Firebox:

Different types and thicknesses of steel will expand and contract at different rates resulting in some "cracking" and "ticking" sounds which will be heard throughout the cycling process.

Maintenance Instructions

- 1) Always turn the gas valve to the off position before cleaning. For relighting, refer to lighting instructions. Keep the burner and control compartment clean by brushing and vacuuming at least once a year. When cleaning the logs, use a clean soft paint brush as the logs are fragile and easily damaged.
- 2) Clean (never when unit is hot) appliance, door and louvers with a damp cloth. Never use an abrasive cleaner. The finishes on louvers and doors may be scratched if abrasives are used to clean them. The heater is finished in a heat resistant paint and should only be refinished with heat resistant paint (not with wall paint). Regency uses StoveBrite Paint - Metallic Black #6309.
- 3) Make a periodic check of the burner for proper position and condition. Visually check the flame of the burner periodically, making sure the flames are steady: not lifting or floating. If there is a problem, call a qualified service person.
- 4) The appliance and venting system must be inspected before use, and at least annually, by a qualified field service person, to ensure that the flow of combustion and ventilation air is not obstructed. During the annual service call, the burners should be removed and cleaned from the burner tray.
- 5) Keep the area near the appliance clear and free from combustible materials, gasoline and other flammable vapours and liquids.

WARNING: CHILDREN AND ADULTS SHOULD BE ALERTED TO THE HAZARDS OF HIGH SURFACE TEMPERATURE AND SHOULD STAY AWAY TO AVOID BURNS OR CLOTHING IGNITION. YOUNG CHILDREN SHOULD BE CAREFULLY SUPERVISED WHEN THEY ARE IN THE SAME ROOM AS THE APPLIANCE.

CAUTION: ANY SAFETY SCREEN OR GUARD REMOVED FOR SERVICING AN APPLIANCE MUST BE REPLACED PRIOR TO OPERATING THE APPLIANCE.

CLOTHING OR OTHER FLAMMABLE MATERIAL SHOULD NOT BE PLACED ON OR NEAR THE APPLIANCE.

- 6) Each time the appliance is lit, it may cause condensation and fog the glass. This condensation and fog is normal and will disappear in a few minutes as the glass heats up.

Never operate the appliance without the glass properly secured in place or with the door open.

- 7) Do not use this appliance if any part has been under water. Immediately call a qualified service technician to inspect the appliance and to replace any part of the control system and any gas control which has been under water.
- 8) Periodically check the pilot flames. Correct flame pattern has three strong blue flames: 1 flowing around the thermopile and 1 around the thermocouple, and 1 flowing across the front of the burner.

Note: If you have an incorrect flame pattern, contact your Regency dealer for further instructions.

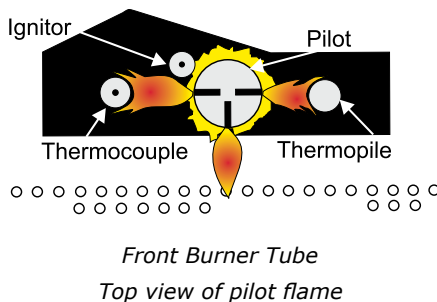

Incorrect flame pattern will have small, probably yellow flames, not coming into proper contact with the rear of the burner or thermopile.

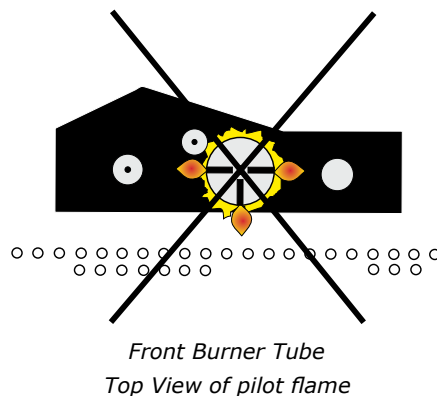

General Vent Maintenance

Conduct an inspection of the venting system semi-annually. Recommended areas to inspect as follows:

- 1) Check the Venting System for corrosion in areas that are exposed to the elements. These will appear as rust spots or streaks, and in extreme cases, holes. These components should be replaced immediately.

- 2) Remove the Termination Cap, and shine a flashlight down the Vent. Remove any bird nests, or other foreign material.
- 3) Check for evidences of excessive condensation, such as water droplets forming in the inner liner, and subsequently dripping out the joints. Continuous condensation can cause corrosion of caps, pipe, and fittings. It may be caused by having excessive lateral runs, too many elbows, and exterior portions of the system being exposed to cold weather.
- 4) Inspect joints to verify that no pipe sections or fittings have been disturbed, and consequently loosened. Also check mechanical supports such as Wall Straps, or plumbers' tape for rigidity.

Log Replacement

The unit should never be used with broken logs. Turn off the gas valve and allow the unit to cool before opening door to carefully remove the logs. The pilot light generates enough heat to burn someone. If for any reason a log should need replacement, you must use the proper replacement log. The position of these logs must be as shown in the diagram under Log Installation.

NOTE: Improper positioning of logs may create carbon build-up and will alter the unit's performance which is not covered under warranty.

Glass Gasket

If the glass gasket requires replacement use a tadpole gasket for the Flush Front Glass (Part # 846-697).

Door Glass

Your Regency insert is supplied with high temperature, 5 mm Neoceram ceramic glass that will withstand the highest heat that your unit will produce. Do not abuse the glass by striking the surface or by slamming the door shut.

If your glass requires cleaning, we recommend using an approved glass cleaner available at all authorized dealers. **Do not use abrasive materials. Do not clean the glass when hot.**

In the event that you break your glass by impact, purchase your replacement from an authorized Regency dealer only, do not use substitute materials. Follow our step-by-step instructions for replacement. **Warning: Wear gloves when removing damaged or broken glass.**

Caution: Do not operate appliance with glass panels removed, cracked or broken. Replacement of the glass should be done by a licensed or qualified service person.

maintenance

Fan Replacement

- 1) Unplug the power source.
- 2) Remove the faceplate.
- 3) Remove the safety screen.
- 4) Remove the glass door.
 - a) Pull the spring hook on the left that holds the door in place. Place the hook into the opening towards the outside of the bracket. Repeat on right side.

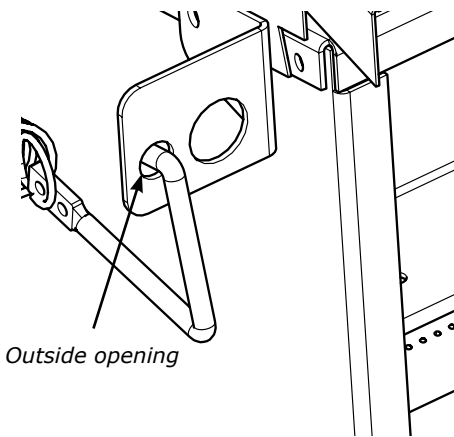
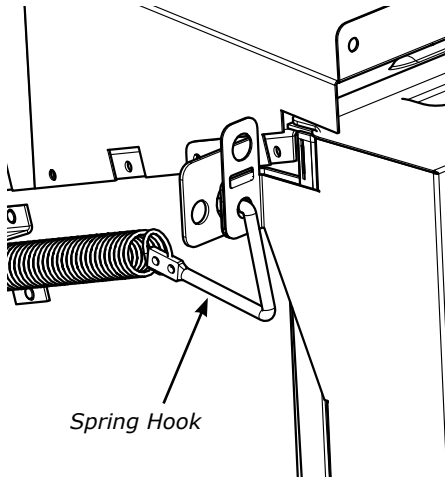

- b) Swing the door out 45 degrees and lift up and out.



- 5) Remove the logs.
- 6) Remove brick panels, if installed.
- 7) Remove the burner by undoing the 3 screws.

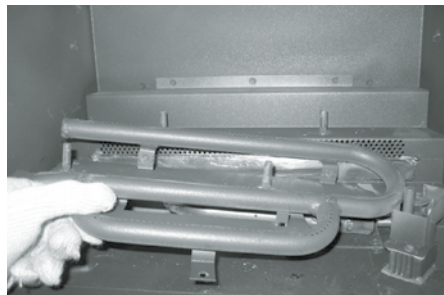
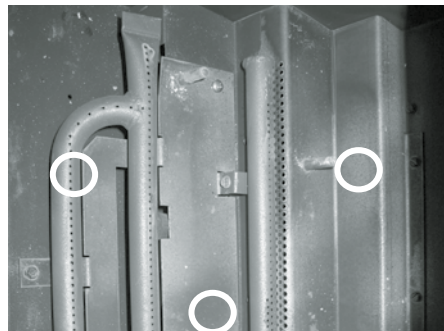

Burner Removed

- 8) Remove the burner tray by undoing the 4 screws.

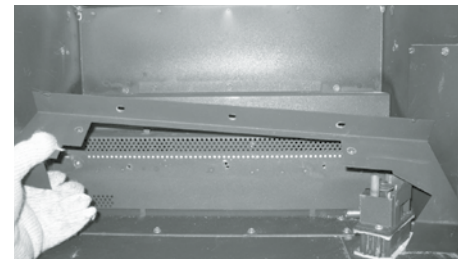
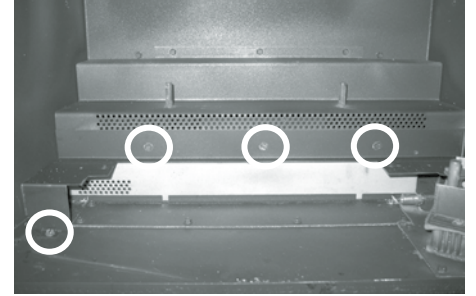

Burner Tray Removed

- 9) Remove the rear log tray by undoing the 3 screws.

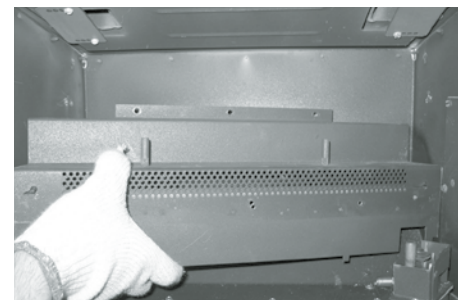
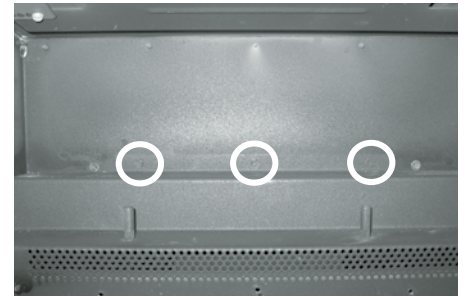

Rear Log Tray Removed

10) Remove the fan cover plate by undoing the 12 screws that hold it in place.

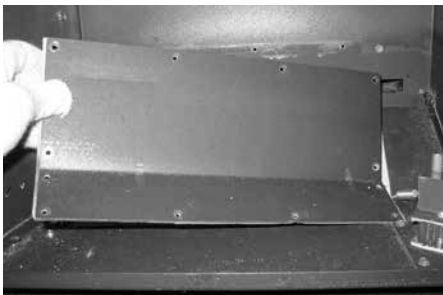
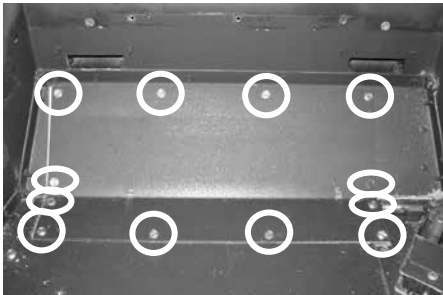

Fan Cover Plate Removed

11) Unplug the fan connector wires.

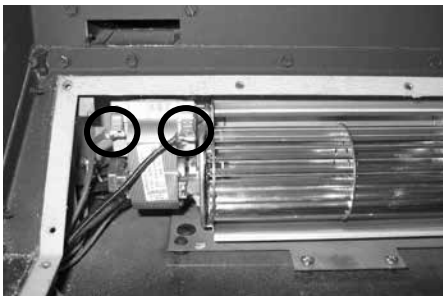

12) Remove the 2 screws that hold the fan bracket in place.

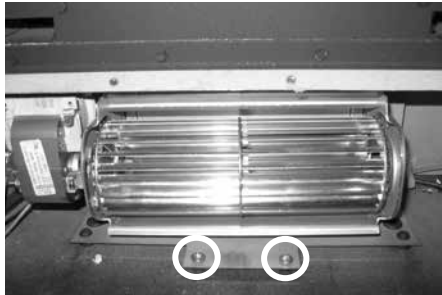

13) Remove the fan by sliding the fan forward and lift up and out.

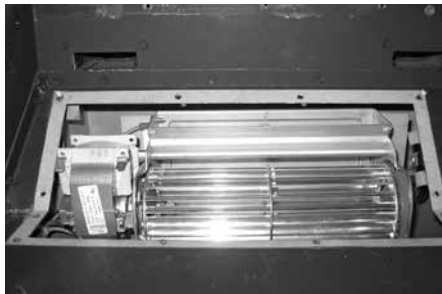

14) Remove the ground screw which holds the ground wire.

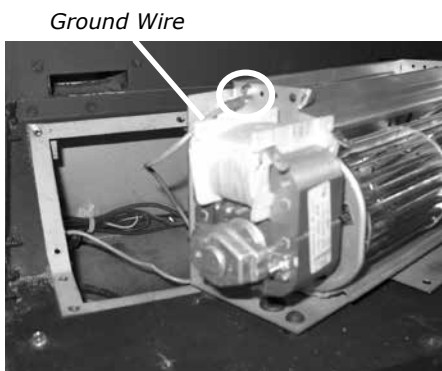

15) Replace the fan.

NOTE: Bend the connector clips down before re-installing the fan cover plate.

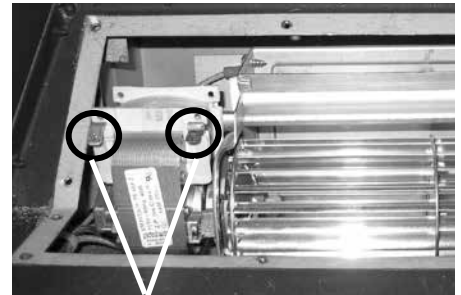

Connector Clips

16) Reverse steps 14 - 1.

maintenance

Valve Replacement

- 1) Remove the faceplate - see instructions in manual.
- 2) Remove the safety screen and glass door.
 - a) Pull the spring hook on the left that holds the door in place. Place the hook into the opening towards the outside of the bracket. Repeat on right side.

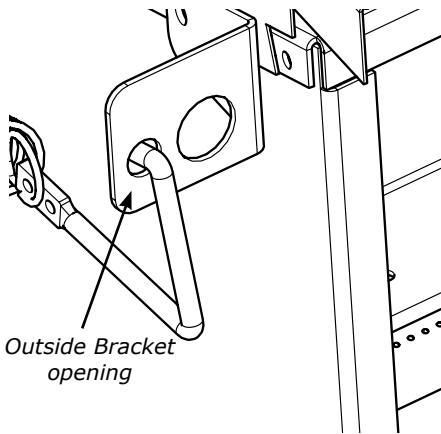
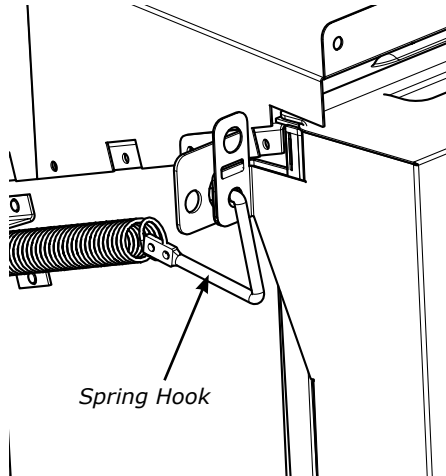

- b) Swing the door out 45 degrees and lift up and out.



- 3) Remove the logs.
- 4) Remove brick panels, if installed.
- 5) Remove the valve shield by undoing the 2 screws.



- 6) Disconnect the gas connection to the valve.
- 7) Disconnect the ignitor wire from the DC Sparker.
- 8) Disconnect the valve wires from the DC Sparker.

DC Sparker Wires



- 9) Unplug the 2 connectors from the valve.



10) Remove the burner by undoing the 3 screws.

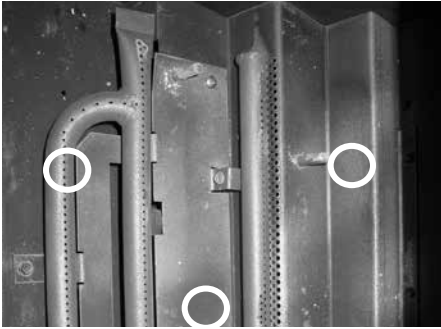

Burner Removed

12) Remove the rear log tray by undoing the 3 screws.

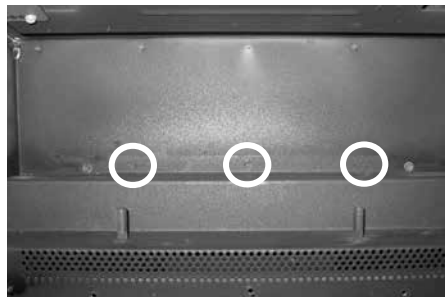

Rear Log Tray Removed

11) Remove the burner tray by undoing the 4 screws.

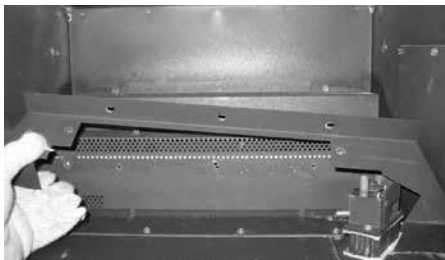
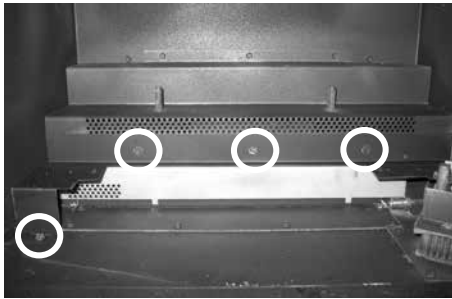

Burner Tray Removed

13) Remove the 12 screws that hold the valve tray to the firebox and carefully pull out.

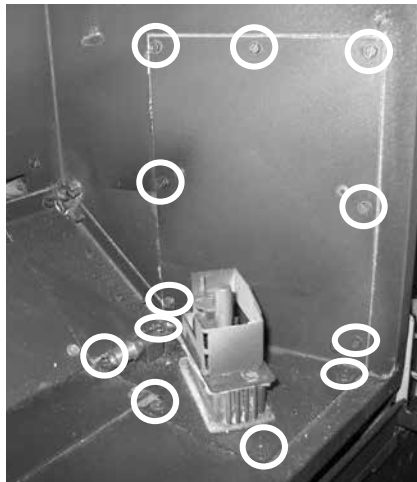

Valve Removed

14) Replace the valve.

15) Reverse steps 13 - 1.

maintenance

Gas Maintenance - Recommended Annual Routine

In order for your Regency appliance to continue to provide comfort to your home periodic maintenance must be performed to ensure it is operating at peak efficiency. The items in the list should be checked by a licensed gas service technician during the annual service check. Your unit may require more frequent maintenance checks if you notice any changes in how it operates. Operational changes to look for can include, but are not limited to, extended start up time, increased fan noise, residue/carbon build up, white build up on the glass/firebox, increased operating noise etc. Should any of these or other conditions arise, discontinue use and schedule a service check with your local licensed gas technician. The list below shows items your licensed service technician will need to check and service at least annually.

Clean

- Glass
- Interior bricks / panels
- Burner ports & burner air shutter
- Fan blades
- Log set
- Pilot orifices
- Pilot hood (change as needed)
- Flame sensor (electronic ignition models)
- Flame electrode
- Burner orifice
- Thermocouple (millivolt models)
- Thermopile (millivolt models)

Inspect

- Pilot assembly
- Burner
- Pressure relief gaskets/doors
- Flue connector gasket if present
- Door seal
- Firebox
- Venting
- Batteries (remote handheld, remote receiver, DC sparker, change as needed)
- Burner media (change as needed)
- Air shutter setting
- Wiring

Check

- Voltage on thermocouple/thermopile (millivolt models)
- Ohms reading on flame sense (electronic ignition models)
- Inlet/outlet fuel pressures as per rating plate
- Voltage/ohms readings on gas valve
- Ohms reading to on/off switch circuit (Millivolt models)

Gas Leak Tests

- Check main gas line connection to valve
- Check shut off valve connections
- Check connection at gas valve outlet
- Check connection at main burner orifice
- Check pilot fuel line at valve and at pilot assembly

Main Assembly

	Part #	Description		Part #	Description
1)	940-355/P	Glass (includes glass gasket)	904-163	Orifice #54 - LP	
1a)	536-539	Door Frame Assembly no Glass	936-170	Orifice Gasket	
1b)	536-540	Door Frame Assembly with Glass			
	846-697	Glass Gasket Tadpole Tape (12') (936-155)	16)	911-268	Valve only - NG
	904-691	Glass U Clip (each) - 4 per unit		911-270	Valve only - LP
	948-463	Burner Assy - NG/LP	17)	537-674/P	Valve Assembly - NG
3)	536-092	Log Tray Middle	17)	537-676/P	Valve Assembly - LP
4)	536-014	Log Tray Rear	19)	910-073	Battery Holder - DC Sparker
5)	536-011	Fan Access Plate		910-074	DC Sparker - Switch
6)	536-107	Gasket - Fan Access Plate	18)	537-001	Safety Screen Frame
7)	536-517/P	Fan Assembly 120 V	18a)	537-000	Safety Screen Mesh
8)	910-215/P	Replacement Fan Motor 120 V		537-002	Safety Screen Insert
	910-794	Power Cord		911-338/P	Remote Receiver
	910-985	Wire Harness (Faceplate) - Black		910-592	Remote Transmitter Handheld GTMF Silver
	910-986	Wire Harness (Faceplate) - Red		911-175/P	Remote Transmitter Handheld GTMF Black
	910-692	Wire Fan to Power Cord Ground	20)	910-373	Pilot Extension Knob
	910-142	Fan Auto On/Off Thermdisc		910-386	Thermocouple
	536-522	Baffle Plate Assembly		910-341	Thermopile
9)	536-901	Brick Panel Set - Standard Brown		910-096	Pilot Hood
9)	536-902	Brick Panel Set - Standard Red		910-036	Pilot Orifice NG
	511-031	Brick Clip		910-037	Pilot Orifice LP
				910-432	Pilot Tube w/nuts
12)	537-515	Flue Adaptor Assembly	25)	910-581	Stepper Motor NG
13)	820-389	Thermdisc Bracket	25)	910-582	Stepper Motor LP
14)	536-091	Pilot Shield		536-106	Thermal Insulation
15)	910-038/P	Pilot Assy- 3 Flame - S.I.T. - NG		536-109	Gasket - Valve Tray
15)	910-039/P	Pilot Assy - 3 Flame - S.I.T. - LP		536-930	Complete Log Set
	904-430	Orifice #42 - NG		902-156	Lava/Embers
				946-669	Platinum Bright Embers
				946-708	Embaglow Bright Embers
				537-969	Conversion Kit LP
				537-940	Hearth Trim
				920-066	Manual

* Not available as a replacement part.

Main Assembly

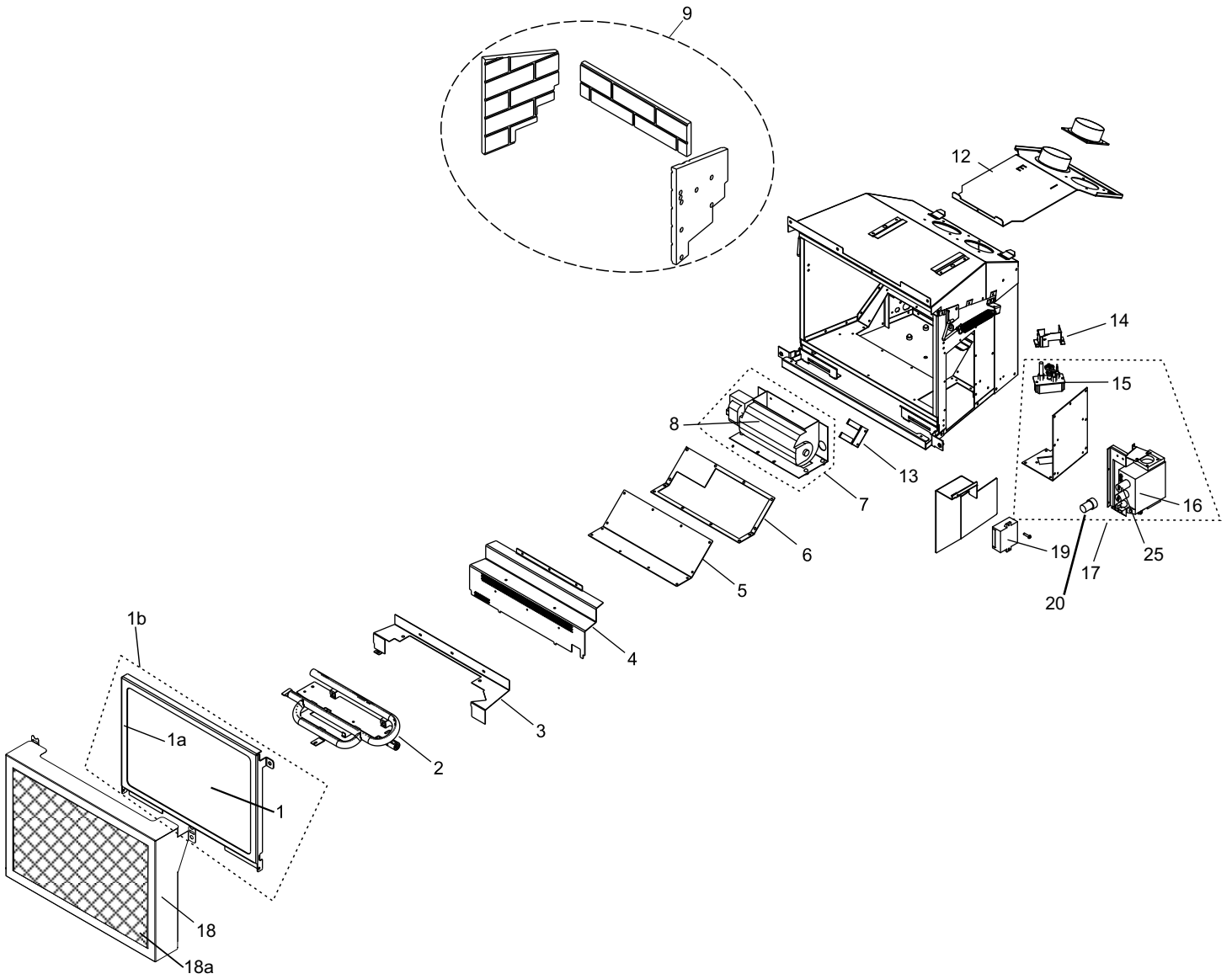

- 537-954 Low Profile Faceplate with Safety Screen
- 910-330 Fan Speed Controller
- 904-586 Fan Speed Controller Knob

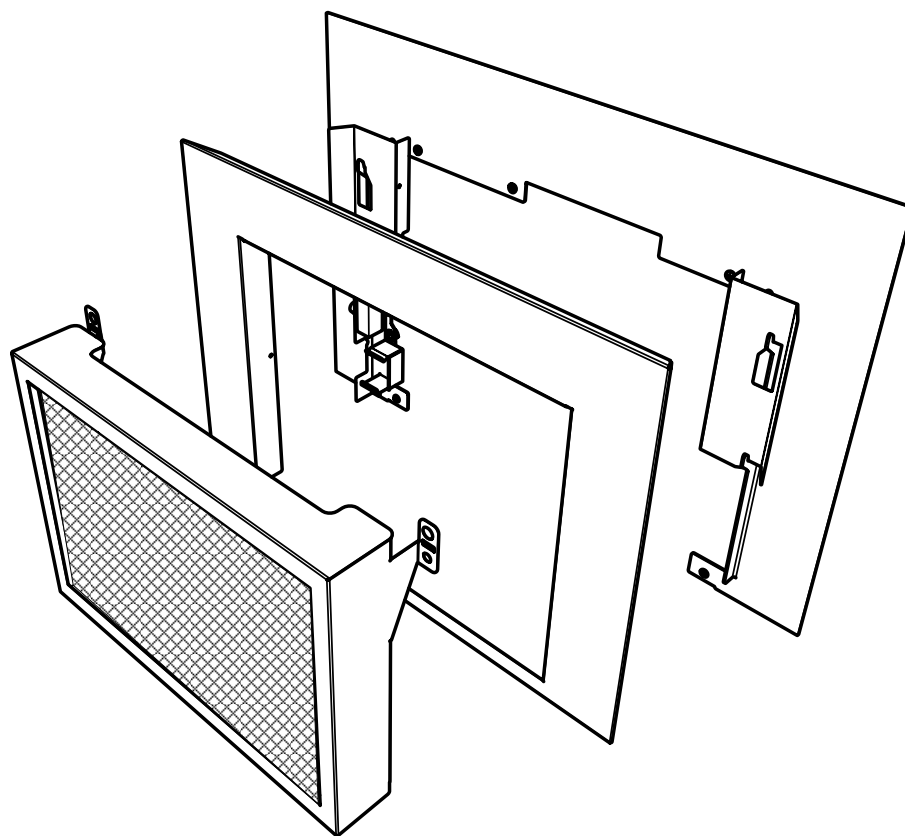

Indoor Gas Product Warranty

Limited Lifetime Warranty

FPI Fireplace Products International Ltd. (for Canadian customers) and Fireplace Products US, Inc. (for US customers) (collectively referred to herein as “FPI”) extends this Limited Lifetime Warranty to the original purchaser of this Appliance provided the product remains in the original place of installation. The items covered by this Limited Lifetime Warranty and the period of such coverage are set forth in the table below.

An Appliance in this policy is defined as an Indoor Gas Fireplace, Indoor Gas Insert, Indoor Gas Freestanding Stove.

This Appliance has only been certified and listed for use indoors.

This Limited Lifetime Warranty starts on the day the Appliance was purchased.

The Limited Lifetime Warranty is not transferable, amendable or negotiable under any circumstances.

Indoor Gas Products Warranty Coverage Parts and Labor	Limited Lifetime	5 years	2 years	1 year	Subsidized Labor Coverage* (Years)
Firebox and Heat Exchanger	✓				3
Steel Burner Tube	✓				3
Glass Thermal breakage only	✓				3
All painted Surrounds/Inlays Finishes		✓			3
Brick Panels/Log sets/Ceramic Burners		✓			3
All Castings		✓			3
Valve assembly and all gas control components (Pilot assembly, flame sensors, Spark Electrode, Pilot Tubing, Orifices, Thermocouple, Thermopile)			✓		2
All Other Electrical components (Ignition Control Boards, Wiring, Switches, Blowers, Blower Control Module, Battery Pack, Remote Control Systems)			✓		2
Enamel Panels			✓		1
Venting/Venting Components			✓		1
All Stainless steel surrounds All black chrome Brushed nickel/Antique copper Faceplates/surrounds All Inner/Outer Black Glass panels				✓	1
All Firebox Media (Crystals, Fire beads, Volcanic, Ceramic, Spa Stones, River Pebbles)				✓	1
All hardware				✓	1
WIFI Dongle				✓	1
Mesh/Glass Safety Barriers				✓	1
Accent Light Bulbs				✓	1
Glass (Crazing)				✓	1

Note: Warranty coverage noted above may not be applicable as components/options vary based on appliance purchased.

Conditions:

Warranty protects against defect in manufacture or FPI factory-assembled components only, unless herein specified otherwise.

***This warranty does not cover dealer travel costs, mileage, fuel, tolls for diagnostic or service work. All labor rates paid to authorized dealers are subsidized, pre-determined rates. Dealers may charge you for travel and additional time beyond their subsidy.**

Any part(s) found to be defective during the warranty period as outlined above will be repaired or replaced at FPI's option through an accredited distributor, dealer or pre-approved and assigned agent; provided that the defective part is returned to the distributor, dealer or agent for inspection if requested by FPI. Alternatively, FPI may, at its discretion, fully discharge all of its obligations under warranty by refunding the verified purchase price of the product to the original purchaser. The purchase price must be confirmed by the original Bill of Sale. **The authorized selling dealer, or an alternative authorized FPI dealer if pre-approved by FPI, is responsible for all in-field diagnosis and service work related to all warranty claims. FPI is not responsible for results or costs of workmanship of unauthorized FPI dealers or agents in the negligence of their service work.**

At all times, FPI reserves the right to inspect reported in the field/on location complaints of products claimed to be defective before processing or authorizing any claim. Failure to allow this upon request will void the warranty.

All warranty claims must be submitted by the dealer servicing the claim, including a copy of the Bill of Sale (proof of purchase by you). All claims must be complete and provide full details as requested by FPI to receive consideration for evaluation. **Incomplete claims may be rejected.**

Replacement Appliances to the original purchaser are limited to one per warranty term. Appliances must be installed according to all manufacturers' instructions as per the manual. All Local and National required codes must be met.

The installer is responsible for ensuring the Appliance is operating as designed at the time of installation.

The original purchaser is responsible for the annual maintenance of the Appliance, as outlined in the owner's manual. As outlined below, the warranty may be voided due to problems caused by a lack of maintenance.

Purchased parts: Repair/replacement parts purchased by the consumer from FPI after the original coverage has expired on the Appliance will carry a **90-day** warranty from the purchase date, valid with a receipt only. Any item shown to be defective will be repaired or replaced at our discretion. No labor coverage is included with these parts.

Special Finishes - One year on brushed nickel, black chrome and antique copper faceplates/surrounds. You can expect some changes in color as the product "ages" with constant heating and cooling. FPI warrants the product for any manufacturing defects on the original product. However, the manufacturer's warranty does not cover changing colors and marks, i.e. fingerprints, etc. applied after the purchase of the product. Damage from the use of abrasive cleaners is not covered by warranty.

If freight damage has been found either externally or internally, the dealer must be informed within 3 days. All claims as a result of damage must be submitted by the dealer servicing the claim, including a copy of the Bill of Sale (proof of purchase). All claims must be complete and provide full details as requested by FPI to receive consideration for evaluation. **Incomplete claims may be rejected.**

As this is a Limited Lifetime Warranty, if the Appliance needs to be replaced, the Appliance that was purchased at the time of sale might not be replaced with exactly the same model Appliance. In that case, FPI will replace your Appliance with one that is similar at the time of replacement under the terms of this Limited Lifetime Warranty, but **ONLY** in the event that an item covered by the Limited Lifetime Warranty is found to be defective. Please refer to the table on first page of this warranty for items covered by the Limited Lifetime Warranty. Product changes might be the result of the original Appliance being discontinued, changes in regulatory requirements, product advancements, etc., which are beyond the control of FPI. **This Limited Lifetime Warranty does not cover any installation costs, or costs associated with changes of required clearances for the replacement Appliance, hearth pads, mantles, facing and/or facing materials such as framing, completed walls made of drywall, wood, non-combustible board, tile, brick, stone, marble etc., venting/chimney systems, or components of the chimney system.**

If a suitable replacement is not available, FPI will refund **50%** of the purchase price of the Appliance and any applicable FPI accessories (faceplates, brick panels, media, etc.) purchased at the time of sale. **In no event will FPI refund any portion of the purchase price of, or reimburse costs associated with, any other items, including without limitation, installation of a new Appliance, changes of required clearances for a new Appliance, hearth pads, mantles, facing and/or facing materials such as framing, completed walls made of drywall, wood, non-combustible board, tile, brick, stone, marble etc., venting/chimney systems, or components of the chimney system. A copy of the receipt or bill of sale will be necessary to validate the purchase price.**

warranty

Exclusions:

This Limited Lifetime Warranty does not extend to paint, rust or corrosion of any kind due to a lack of maintenance or improper venting, combustion air provision, corrosive chemicals (i.e. chlorine, salt, air, etc.), door or glass gasketing, batteries, color fading, carbon/sooting of the log sets due to use and does not cover lava rock, platinum/glowing embers, vermiculite.

Malfunction, damage or performance-based issues as a result of environmental conditions, location, chemical damages, downdrafts, installation error, an installation by an unqualified installer, incorrect chimney components (including but not limited to cap size or type), operator error, abuse, misuse, use of improper fuels, lack of regular maintenance and upkeep, acts of God, weather-related problems from hurricanes, tornados, earthquakes, floods, lightning strikes/bolts or acts of terrorism or war, which result in a malfunction of the Appliance are not covered under the terms of this Limited Lifetime Warranty.

FPI has no obligation to enhance or modify any Appliance once manufactured (i.e. as products evolve, field modifications or upgrades will not be performed on existing Appliances).

Any Appliance showing signs of neglect or misuse will not be covered under the terms of this warranty policy and may void this warranty, including Appliances with rusted or corroded fireboxes that have not been reported as rusted or corroded within **three (3)** months of installation/purchase.

Appliances which show evidence of being operated while damaged, or with problems known to the purchaser and causing further damages will void this warranty.

Appliances where the serial no. has been altered, deleted, removed or made illegible will void this warranty.

Minor movement, expansion and contraction of the steel is normal and is not covered under the terms of this warranty.

Freight damages for products or parts are not covered under the terms of the warranty.

Products made or provided by other manufacturers and used in conjunction with the FPI Appliance without prior authorization from FPI may void this warranty.

Limitations of Liability:

The original purchaser's exclusive remedy under this warranty, and FPI's sole obligation under this Limited Lifetime Warranty, express or implied, in contract or in tort, shall be limited to replacement, repair, or refund, as outlined above. IN NO EVENT WILL FPI BE LIABLE UNDER THIS WARRANTY FOR ANY INCIDENTAL OR CONSEQUENTIAL COMMERCIAL DAMAGES OR DAMAGES TO PROPERTY. TO THE EXTENT PERMITTED BY APPLICABLE LAW, FPI MAKES NO EXPRESS WARRANTIES OTHER THAN THE WARRANTY SPECIFIED HEREIN. THE DURATION OF ANY IMPLIED WARRANTY IS LIMITED TO DURATION OF THE EXPRESSED WARRANTY SPECIFIED ABOVE. IF IMPLIED WARRANTIES CANNOT BE DISCLAIMED, THEN SUCH WARRANTIES ARE LIMITED IN DURATION TO THE DURATION OF THIS WARRANTY.

Some US states do not allow limitations on how long an implied warranty lasts, or allow exclusion or limitation of incidental or consequential damages, so the above limitations or exclusions may not apply to you.

Customers located outside the US should consult their local, provincial or national legal codes for additional terms, which may apply to this warranty.

How to Obtain Warranty Service:

Customers should contact the authorized selling dealer to obtain warranty service. In the event the authorized selling dealer is unable to provide warranty service, please contact FPI by mail at the address listed below. Please include a brief description of the problem and your address, email and telephone contact information. A representative will contact you to make arrangements for an inspection and/or warranty service.

Canadian Warrantor:**FPI Fireplace Products International Ltd.**

6988 Venture St.
Delta, British Columbia
Canada, V4G 1H4

U.S. Warrantor:**Fireplace Products US, Inc.**

PO Box 2189 PMB 125
Blaine, WA
United States, 98231

Or contact the Regency Customer Care Centre at 1-800-442-7432 (phone) / 604-946-4349 (fax)
/customerservice@regency-fire.com (e-mail)

Product Registration and Customer Support:

Thank you for choosing a Regency Fireplace. Regency strives to be a world leader in the design, manufacture, and marketing of hearth products. To provide the best support for your product, we request that you complete a product registration form at <http://www.regency-fire.com/Customer-Care/Warranty-Registration.aspx> within **ninety (90)** days of purchase.

Warranty Registration Card



Product Registration and Customer Support:

Thank you for choosing a Regency Fireplace. Regency strives to be a world leader in the design, manufacture, and marketing of hearth products. To provide the best support for your product, we request that you complete a product registration form found on our Web Site under Customer Care within ninety (90) days of purchase.

For purchases made in **CANADA or the UNITED STATES:**

<http://www.regency-fire.com/Customer-Care/Warranty-Registration.aspx>

For purchases made in AUSTRALIA:

<http://www.regency-fire.com.au/Customer-Care/Warranty-Registration.aspx>

You may also complete the warranty registration form below to register your Regency Fireplace Product and mail and/or fax it back to us, and we will register the warranty for you. It is important you provide us with all the information below in order for us to serve you better.

Warranty Registration Form (or Register online immediately at the above Web Site):

Warranty Details	
Serial Number (required):	
Purchase Date (required) (mm/dd/yyyy):	
Product Details	
Product Model (required):	
Dealer Details	
Dealer Name (required):	
Dealer Address:	
Dealer Phone #:	
Installer:	
Date Installed (mm/dd/yyyy):	
Your Contact Details (required)	
Name:	
Address:	
Phone:	
Email:	

For purchases made in CANADA:

FPI Fireplace Products International Ltd.
6988 Venture St.
Delta, British Columbia
Canada, V4G 1H4

Phone: 604-946-5155
Fax: 1-866-393-2806

For purchases made in the UNITED STATES:

Fireplace Products US, Inc.
PO Box 2189 PMB 125
Blaine, WA
United States, 98231

Phone: 604-946-5155
Fax: 1-866-393-2806

For purchases made in AUSTRALIA:

Fireplace Products Australia Pty Ltd
99 Colemans Road
Dandenong South, Vic.
Australia, 3175

Phone: +61 3 9799 7277
Fax: +61 3 9799 7822

For fireplace care and tips and answers to most common questions please visit our Customer Care section on our Web Site. Please feel free to contact your selling dealer if you have any questions about your Regency product.

recycling

PRODUCT LIFE CYCLE:

By recycling your used appliances, you divert waste from your local landfills and help the environment. You also reduce the need for raw materials to manufacture new products. Contact your local municipality for appliance recycling services, local recycling programs, or appliance removal services to ensure your Regency appliance components, and packaging are properly recycled.

Installer: Please complete the following information

Dealer Name & Address: _____

Installer: _____

Phone #: _____

Date Installed: _____

Serial #: _____



Liberty L234 Product Video